

TM 11-7025-232-10

OPERATOR'S MANUAL

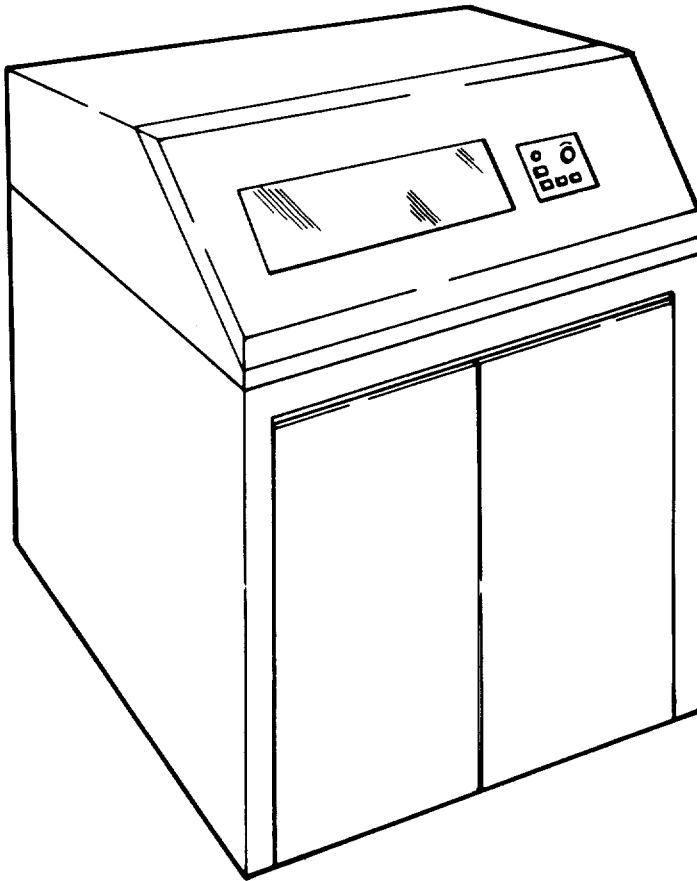

EQUIPMENT
DESCRIPTION
PAGE 1-3

PMCS
PAGE 2-5

OPERATION
PAGE 2-8

TROUBLESHOOTING
PROCEDURES
PAGE 3-1

MAINTENANCE
PROCEDURES
PAGE 3-10

**LINE PRINTER
RP-309/MYQ-4A
(NSN-7010-01-177-0646)**

HEADQUARTERS DEPARTMENT OF THE ARMY

13 MAY 1985

WARNING

HIGH VOLTAGE

High voltage is used in the operation of this equipment.

ELECTROCUTION ON CONTACT

Electrocution may result if you fail to observe these safety precautions.

Never perform maintenance on this equipment when it is powered on. If you have operating problems or equipment failure, power off and report the problem to your supervisor.

FLAMMABLE AGENTS

Isopropyl alcohol is flammable. Keep away from high heat and open flame.



5

SAFETY STEPS TO FOLLOW IF SOMEONE IS THE VICTIM OF ELECTRICAL SHOCK

- 1** DO NOT TRY TO PULL OR GRAB THE INDIVIDUAL
- 2** IF POSSIBLE, TURN OFF THE ELECTRICAL POWER
- 3** IF YOU CANNOT TURN OFF THE ELECTRICAL POWER, PULL, PUSH, OR LIFT THE PERSON TO SAFETY USING A WOODEN POLE OR A ROPE OR SOME OTHER INSULATING MATERIAL
- 4** SEND FOR HELP AS SOON AS POSSIBLE
- 5** AFTER THE INJURED PERSON IS FREE OF CONTACT WITH THE SOURCE OF ELECTRICAL SHOCK, MOVE THE PERSON A SHORT DISTANCE AWAY AND IMMEDIATELY START ARTIFICIAL RESUSCITATION

OPERATOR'S MANUAL
LINE PRINTER RP-309/MYQ-4A

REPORTING ERRORS AND RECOMMENDING IMPROVEMENTS

You can help improve this manual. If you find any mistakes or if you know of a way to improve the procedures, please let us know. Mail your letter, DA Form 2028 (Recommended Changes to Publications and Blank Forms), or DA Form 2028-2 located in back of this manual, direct to: Commander, US Army Communications and Electronics Command and Fort Monmouth, ATTN: DRSEL-ME-MP, Fort Monmouth, New Jersey 07703. A reply will be furnished to you.

		Page
	HOW TO USE THIS MANUAL	v
CHAPTER 1	INTRODUCTION	1-1
Section I	General Information	1-1
Section II	Equipment Description	1-3
Section III	Technical Principles of Operation	1-12
CHAPTER 2	OPERATING INSTRUCTIONS	2-1
Section I	Description and Use of Operator's Controls and Indicators	2-1
Section II	Preventive Maintenance Checks and Services	2-5
Section III	Operation Under Usual Conditions	2-8
Section IV	Operation Under Unusual Conditions	2-40
CHAPTER 3	MAINTENANCE INSTRUCTIONS	3-1
Section I	Lubrication Instructions	3-1
Section II	Troubleshooting Procedures	3-1
Section III	Maintenance Procedures	3-10
APPENDIX A	REFERENCES	A-1
APPENDIX B	COMPONENTS OF END ITEM AND BASIC ISSUE ITEMS LISTS.	B-1
APPENDIX C	ADDITIONAL AUTHORIZATION LIST	C-1
APPENDIX D	EXPENDABLE SUPPLIES AND MATERIALS LIST	D-1

HOW TO USE THIS MANUAL

This manual tells you how to operate and service Line Printer RP-309/MYQ-4A.

LOCATION OF SUBJECTS IN MANUAL

In this manual, paragraphs are numbered in order by chapter. For example, paragraph 2-3 is the third paragraph in chapter 2. Pages are also numbered this way. Using this numbering system, there are two easy ways to locate the information you need in this manual.

- Front cover locators
- Subject index

Use the front cover locators and marked pages to quickly find the parts of the manual shown on the cover. If the information you need is not listed on the front cover, use the subject index at the back of this manual. It lists all subjects covered in the manual and directs you to the subject by page number.

OPERATING AND MAINTENANCE PROCEDURES

Operating and maintenance procedures in this manual have two features which help you perform them more easily:

- Initial setup boxes
- First-time performance aids

An initial setup box is used at the start of any procedure which requires setup items before you perform it. This box lists items such as tools and supplies needed to perform the procedure. If the box does not appear at the start of a procedure, it means no setup items are needed.

If You are using this manual to perform a procedure for the first time, always read through the entire procedure before you start. This will help you understand the task you will perform. Always perform the task steps in the order given. This will help assure correct performance. Use the illustrations beside the steps to find the parts of the equipment called out in the steps. Some steps include a reference to another paragraph. Go to that paragraph if you are not sure how the steps are done.

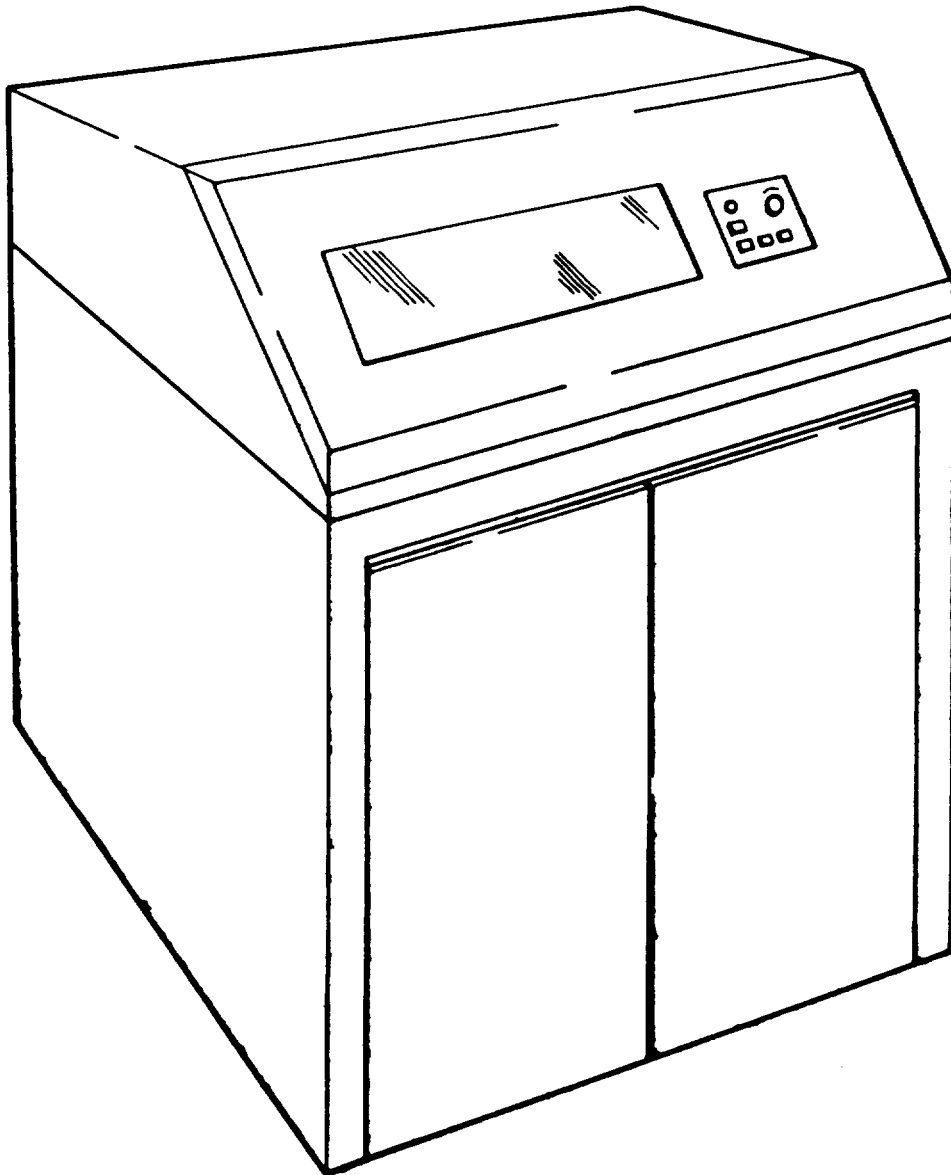

Figure 1-0. Line Printer RP-309/MYQ-4A

CHAPTER 1 INTRODUCTION

Section I. GENERAL INFORMATION

1-1. SCOPE

This manual is the operator's manual for Line Printer RP-309/MYQ-4A (fig. 1-0). In the rest of this manual it will be called the line printer, or printer. This manual describes the line printer and tells what it can do. It also shows you how to operate and maintain it.

The line printer prints computer output data on continuous-form paper.

1-2. MAINTENANCE FORMS AND RECORDS

Department of the Army forms and procedures used for equipment maintenance will be those prescribed by TM 38-750, The Army Maintenance Management System (TAMMS).

1-3. HAND RECEIPT (-HR) MANUALS

This manual has a companion document with a TM number followed by -HR (which stands for Hand Receipt). TM 11-7025-210-10-HR consists of preprinted hand receipts (DA Form 2062) that list end item related equipment (i.e., COEI, BII, and AAL) which you must account for. As an aid to property accountability, additional -HR manuals may be requisitioned from the following source in accordance with procedures in Chapter 3, AR310-2: The U.S. Army Adjutant General Publications Center ATTN: AGLD-OD 2800 Eastern Boulevard, Baltimore, MD 21220.

1-4. REPORTING EQUIPMENT IMPROVEMENT RECOMMENDATIONS (EIR)

If your line printer needs improvement, let us know. Send us an EIR. You, the user, are the only one who can tell us what you don't like about your equipment. Let us know why you don't like the design or performance. Put it on an SF 368 (Quality Deficiency Report). Mail it to us at Commander, US Army Communications and Electronics Command and Fort Monmouth, ATTN: DRSEL-ME-MP Fort Monmouth, New Jersey 07703. We'll send you a reply.

1-5. REFERENCE INFORMATION

This listing includes the nomenclature cross reference list, list of abbreviations, and an explanation of terms (glossary) used in this manual.

1-6. NOMENCLATURE CROSS-REFERENCE LIST

Common names are used throughout this manual, but you must use the official nomenclature when filling out report forms, sending an EIR, or finding referenced technical manuals.

<u>Common Name</u>	<u>Nomenclature</u>
Line Printer or Printer	Line Printer RP-309/MYQ-4A

1-7. LIST OF ABBREVIATIONS

BOF	Bottom of Form
CPU	Central Processing Unit
dBA	decibels adjusted
gsm	grams per square meter
lpi	lines per inch
PROM	Programmable Read Only Memory
TOF	Top of Form
VFU	Vertical Format Unit

1-8. GLOSSARY

Acoustic Cabinet	Printer enclosure designed to reduce hammer noise.
Alphanumeric Code	Numbers and/or letters used to signify operational functions or malfunctions.
Bit	Smallest unit of information handled by the CPU.
Decibel	A unit for measuring the loudness of sounds in relation to human hearing.
Form	The printing surface on pin-feed, fanfold paper.
Interlock	Safety switch that powers off a device under certain conditions such as when an access cover is opened.
Pin-feed, Fanfold Paper	Paper with pin-holes that is advanced by sprockets through the printer, and folds in accordion-like fashion. Also called continuous form paper.
PROM	Programmable Read Only Memory. A high speed permanently coded metal oxide semiconductor memory that can be erased and reprogrammed.
Scalloped Edges	A series of rounded projections on the top edge of the character band.
Slew	The rapid continuous flow of pin-feed paper during printout of forms.

Section II. EQUIPMENT DESCRIPTION

1-9. EQUIPMENT PURPOSE, CAPABILITIES, AND FEATURES

The line printer is a compact, medium speed, impact type printer that produces hard copy printout for use with automated data processing systems. It is enclosed in an acoustic cabinet to reduce operational noise. It can:

- Print up to 1100 lines per minute with a rapidly rotating horizontal character band
- Produce up to six part printout
- Print 10 characters per inch horizontally
- Print six or eight lines per inch vertically
- Print 132 characters per line
- Print on a variety of paper form lengths
- Use a Vertical Format Unit (VFU) to begin printing at top of form, and advance paper rapidly within individual paper forms
- Self test operational functions
- Indicate and define printer faults by display of digital codes on control panel

1-10. LOCATION AND DESCRIPTION OF MAJOR COMPONENTS

Major components of the line printer are the acoustic cabinet, paper handling components, print mechanism, and cooling system.

1-11. ACOUSTIC CABINET

The acoustic cabinet (fig. 1-1) houses the printer, absorbs noise, and provides space for paper storage.

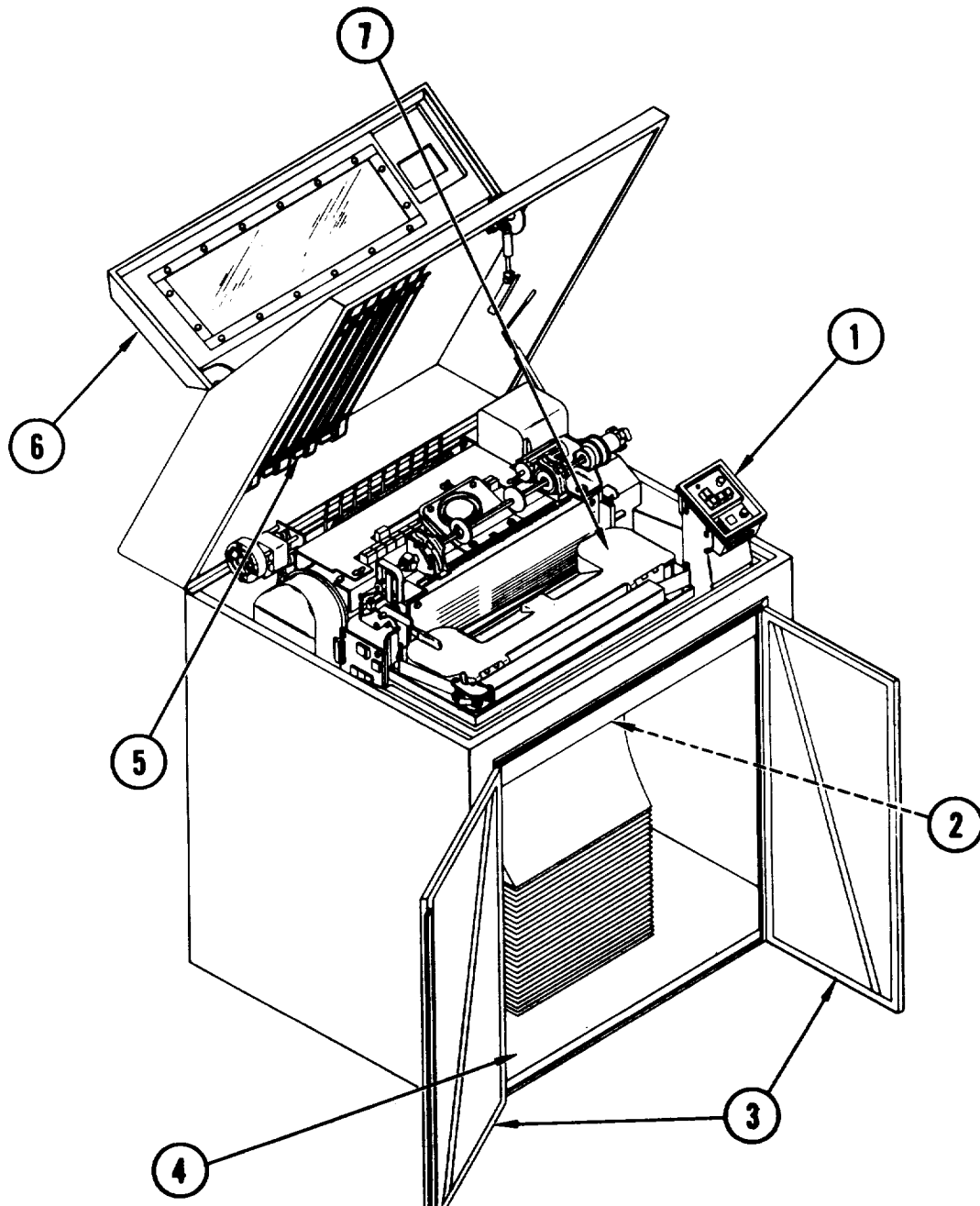

- ① Control Panel - Contains operator controls.
- ② Paper Throat Entrance - Provides opening for paper feed.
- ③ Front Cabinet Doors - Provide access to front paper compartment.
- ④ Front Paper Compartment - Provides space for paper.
- ⑤ Paper Support - Supports paper as it moves into paper puller assembly.
- ⑥ Operator Door - Provides operator access to control panel, paper handling components, and print mechanism.
- ⑦ Band Cover - Protective shield that covers rapidly rotating character band, ribbon and VFU assembly.

Figure 1-1. Acoustic Cabinet (1 of 2)

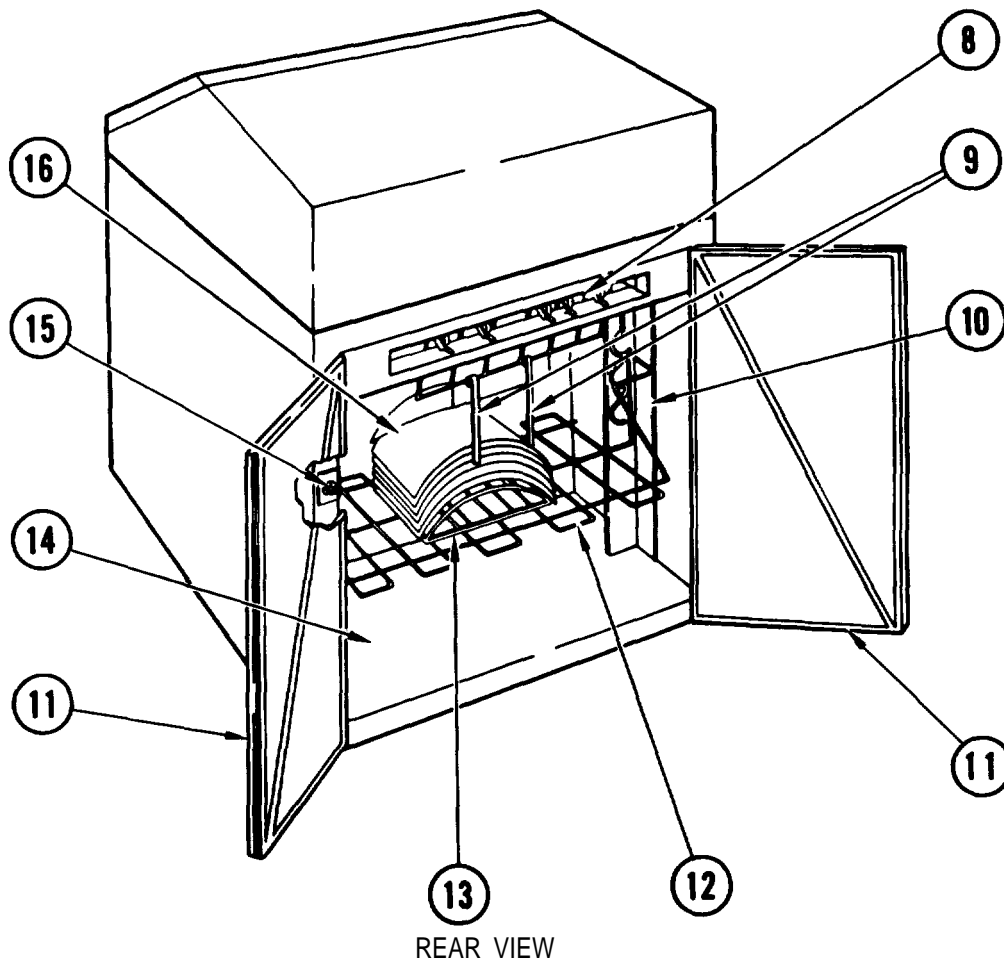

- ⑧ Paper Puller Rollers - Five snap-up/snap-down pressure rollers that distribute tension evenly on paper as it is pulled through printer and down to paper shelf.
- ⑨ Paper Guides - Guide and help paper fold evenly onto arched base.
- ⑩ Paper Shelf Rails - Provide support for movable paper shelf.
- ⑪ Rear Cabinet Doors - Provide access to rear paper compartment.
- ⑫ Paper Shelf - Movable rack which collects fan-fold paper as it slews through the printer.
- ⑬ Arched Shelf - Optional type of paper shelf. Bends paper printout for easy paper pickup and removal by operator.
- ⑭ Rear Paper Compartment - Provides space for printout paper.
- ⑮ POWER ON/OFF Switch - Controls ac power to printer.
- ⑯ Paper - Loads through front compartment; slews through printer to paper shelf inside rear compartment.

Figure 1-1. Acoustic Cabinet (2 of 2)

1-12. PAPER HANDLING COMPONENTS

Paper handling components (fig. 1-2) guide and advance paper through the printer and power off the printer when a paper motion fault occurs.

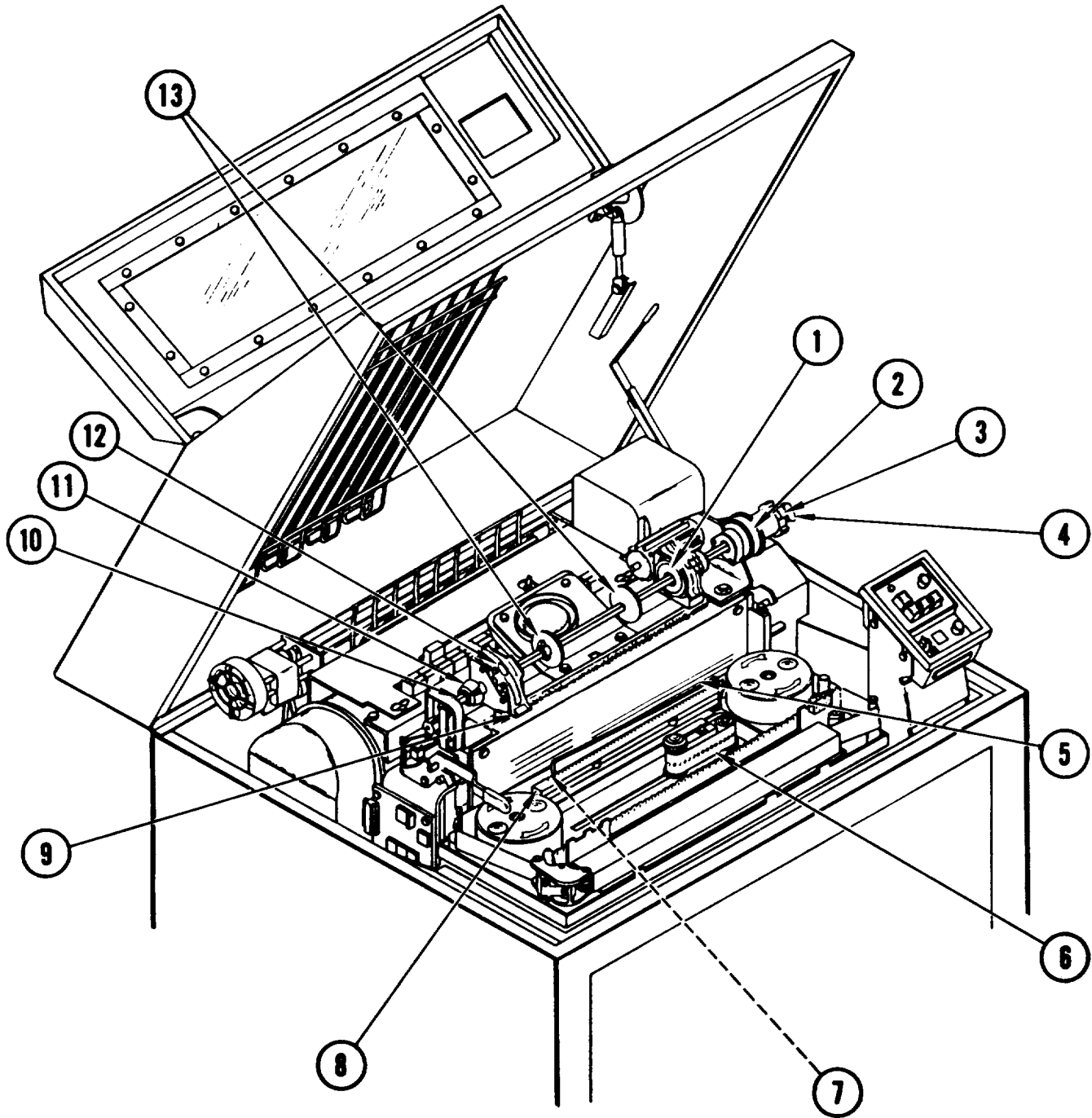

Figure 1-2. Paper Handling Components (1 of 2)

- ① Paper Drive Sprockets (one on each side) - Advance pin-feed paper.
- ② Paper Feed Clutch - Activates paper drive sprockets when connected to drive shaft.
- ③ Vertical Adjust Knob - Used to adjust paper top of form with TOP OF FORM index markings.
- ④ Paper Release Lever - Releases paper from control of paper feed clutch, and allows paper to be advanced manually.
- ⑤ Top of Form Index Markings - Provides guide for adjusting paper top of form.
- ⑥ Vertical Format Unit - Advances paper to top of form, and slews within individual paper forms.
- ⑦ Paper Out Switch - Stops printer operation when paper supply runs out.
- ⑧ Character Alinement Decal - Provides guide for alining paper horizontally with desired character printout position.
- ⑨ Paper Motion Sensor - Senses paper motion and stops printer operation when a motion fault occurs.
- ⑩ Drive Shaft - Rotates paper drive sprockets when paper feed clutch is engaged.
- ⑪ Sprocket Locks (one on each side) - Lock paper drive sprockets into position on drive shaft. Unlock to permit horizontal sprocket movement.
- ⑫ Sprocket Covers (one on each side) - Hold pin-feed paper securely on sprocket pins.
- ⑬ Paper Guides - Guide and provide support for paper as it advances over hammer bank assembly into paper support.

Figure 1-2. Paper Handling Components (2 of 2)

1-13. PRINT MECHANISM

The print mechanism (fig. 1-3) consists of the hammer bank, character band, ribbon and ribbon cartridge, and related components that produce forms printout or power off the printer when a print fault occurs.

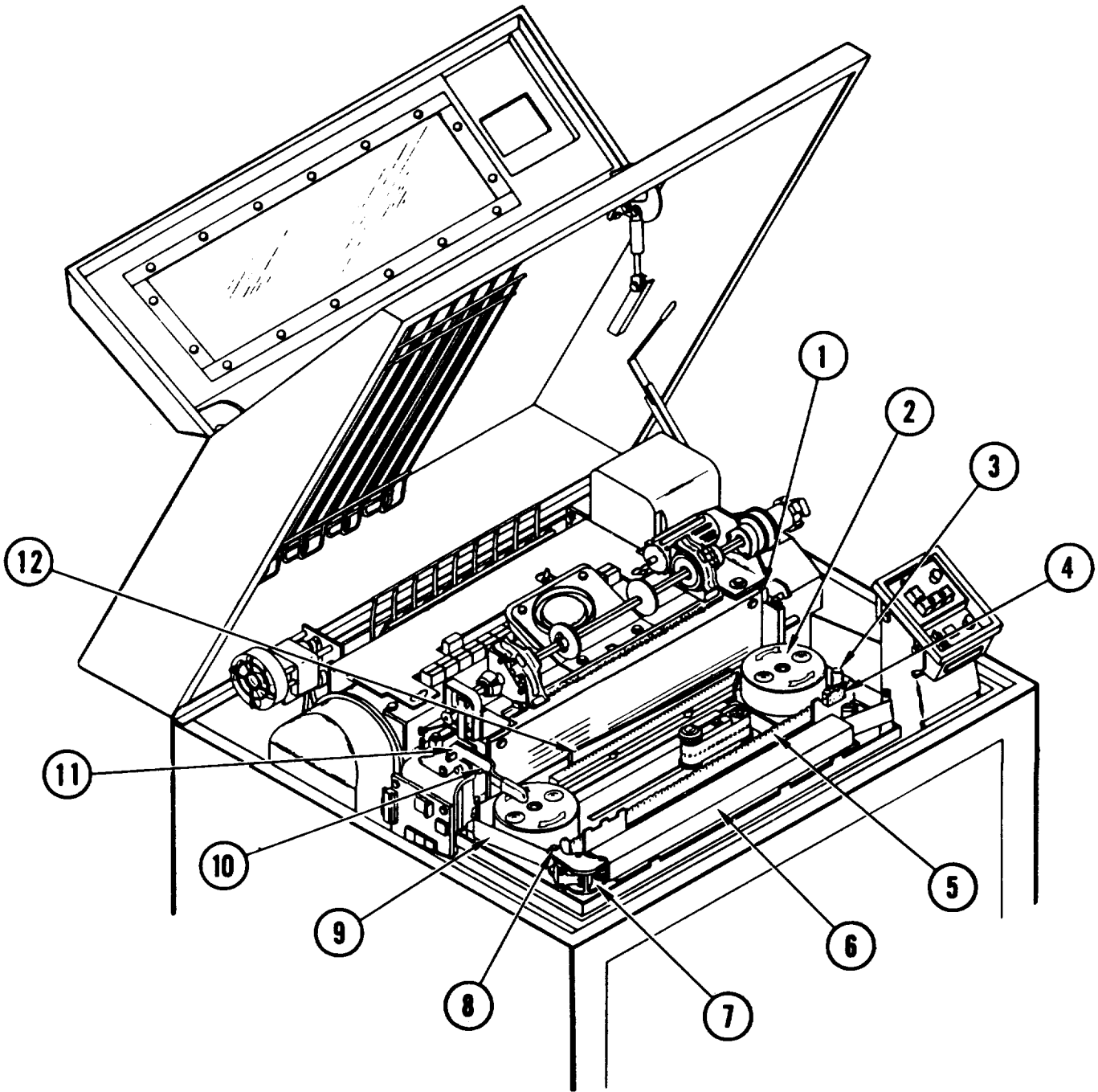

Figure 1-3. Print Mechanism (1 of 2)

- ① Hammer Bank Assembly - Contains hammers that strike against paper, ribbon, and character band to imprint characters on paper.
- ② Band Pulleys (one on each side) - Drive character band.
- ③ Band Release Handle - Releases tension and creates tension on character band.
- ④ Band Cover Interlock Switch - Stops print operation when band cover is open.
- ⑤ Character Band - Continuous metal band with raised characters. Moves counter-clockwise around band pulleys and across print station.
- ⑥ Ribbon Cartridge - Stores total length of ribbon except portion passing across print station.
- ⑦ Ribbon Sensing System - Senses ribbon motion and stops printer operation when ribbon jam or lack of motion is detected.
- ⑧ Pivot Arm Assembly - Contains ribbon drive rollers and ribbon sensing system.
- ⑨ Ribbon - Continuous loop of ink-filled nylon that moves counterclockwise around ribbon guides and diagonally across print station.
- ⑩ Hammer Bank Interlock Switch - Stops printer operation when hammer bank assembly is open.
- ⑪ Hammer Bank Latch Handle - Locks hammer bank into print position or releases it to slide freely on stationary rails.
- ⑫ Platen - Stationary metal bar which acts as a backstop for print hammers during print operation.

Figure 1-3. Print Mechanism (2 of 2)

1-14. COOLING SYSTEM

The cooling system (fig. 1-4) consists of three fans which circulate air through the printer to keep it from overheating.

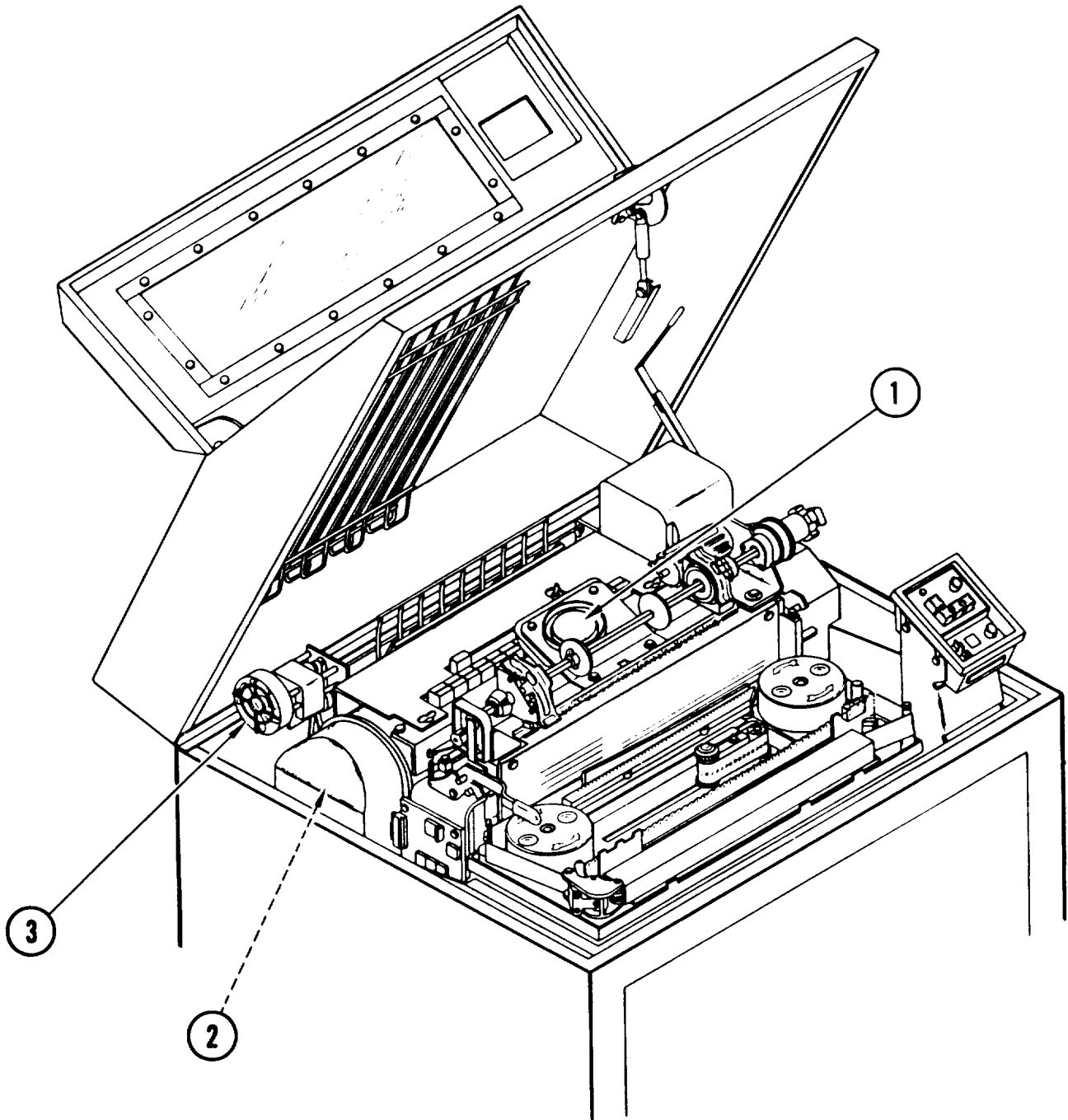

- ① Hammer Bank Blower Fan - Circulates cooling air around the print hammers.
- ② Card Cage Fan - Circulates cooling air over circuit boards.
- ③ Paper Puller Fan - Circulates cooling air over paper motion path.

Figure 1-4. Cooling System

1-15. EQUIPMENT DATA

Weight and Dimensions:

Weight		351.00 lb. (159.2 kg)
Height		44.50 in. (113.0 cm)
	(with operator door open)	58.50 in. (148.5 cm)
	(with top open)	65.20 in. (165.5 cm)
Width		34.40 in. (87.3 cm)
Depth	(with all doors closed)	29.70 in. (75.4 cm)
	(with front doors open)	45.30 in. (115.0 cm)
	(with rear doors open)	45.30 in. (115.0 cm)
	(with front and rear doors open)	60.90 in. (154.7 cm)

Operating Environment:

Temperature	50°F to 100°F (10°C to 38°C)
Relative Humidity	20% to 80% (noncondensing)

Power Requirements:

Voltage	90 V ac to 132 V ac
Frequency	60 Hz

Acoustic Characteristics:

Operating	60 dBA
Standby	54 dBA

Paper Requirements:

Type	Standard Fanfold, Pin-Feed
Width	3.0 in. to 16.0 in. (7.62 cm to 40.64 cm)
Form Length	(at eight lpi) maximum 17.87 in. (45.40 cm)
	(at six lpi) maximum 23.83 in. (60.54 cm)
Weight	(single copy) minimum 15 lb (56 gsm) bond
	recommended 18 to 20 lb (68 to 75 gsm) bond
	(multi-copy) 12 lb (45 gsm) bond with 6 to 8 lb (14 to 19 gsm)
	single-shot carbon for up to 6 parts
	(card stock) 15 to 125 lb (56 to 470 gsm)
Thickness	(maximum) 0.02 in. (0.5 mm)

Ribbon Requirements:

Thickness	0.005 in (0.127 mm)
Length	50 yds (45 meters)
	75 yds (67.5 meters)

Section III. TECHNICAL PRINCIPLES OF OPERATION

1-16. FUNCTIONAL DESCRIPTION

The line printer functions as an output terminal which produces hard copy printout for use with an automated data processing system. When on line under control of a system Central Processing Unit (CPU), the line printer serves as a parallel-input terminal capable of receiving 8 bits at a time. Maximum print rate on line is 132 characters at 1060 lines per minute at a print density of 6 or 8 lines per inch. Functions, once implemented under hardware control by the operator, are under control of the printer processor circuit board. Interface with the system CPU is accomplished by the interface circuit board. The processor circuit board functions as the computing center of the printer system. It controls and stores the printable data, performs the comparison between user-generated character codes for characters on the print line and character codes for characters on the print band. The processor also decodes control characters into system commands and stores Vertical Format Unit (VFU) data. There is also a timing and status circuit board which interfaces with the processor circuit board to monitor printer operation such as control and synchronization of the character band and firing of the hammers. The timing and status board also contains circuitry which detects power supply and operational fault such as printer hot condition, band speed faults, band drive overcurrent conditions. Operational condition and fault codes are displayed on the control panel status indicator. These digital codes (table 3-1) are used during operation and troubleshooting.

1-17. SELF-TEST MODE

A self-test mode is provided as an operator aid to check printer operation and to allow printer troubleshooting without the need of an external system exerciser program. Self test may be selected by placing the TEST switch on the control panel to either the left or right operating position, then placing the printer on line by pressing the ON/OFF LINE switch. After the printer has been placed on line by pressing the ON/OFF LINE switch, the processor circuit board will then inhibit the interface data load mode, allowing the data buffer to be loaded from printer internal sources rather than from the user system. With the TEST switch in the right hand position, pressing the ON/OFF LINE switch will cause the printing of a sliding pattern. Placing the switch in the left hand position will cause the printing of a fixed character pattern. After printing in either the sliding or fixed position, the switch may be moved to the center position. The printer will remain in the self-test mode, printing the same pattern previously printed at one-half full printer speed. Should a fault or interlock condition be detected, the processor circuit board will take the printer off line and direct an appropriate fault code to be displayed on the control panel STATUS indicator. A status code of 66 or 67 indicates that the printer is in the self-test mode. The self test is terminated when the ON/OFF LINE switch on the control panel is pressed, and the TEST switch is then placed in the OFF position.

1-18. PRINTER MECHANISM

The printer mechanism which is housed in the upper level of the acoustic cabinet forward of the logic cards consists of a character band drive system, a ribbon drive system, the form movement mechanism, a printer subsystem, and a power subsystem.

a. Character Band Drive System. The character band is a continuous steel loop which contains the raised print characters, and the necessary timing and index marks. The character band produces print characters with a horizontal spacing of ten characters per inch. The character band is mounted directly under a hinged cover behind the ribbon cartridge. The character band, which is operator replaceable, is mounted over two pulleys, one of which is driven by a dc motor which rotates the character band in a counterclockwise direction at a constant velocity. Vertical travel of the band is controlled by tension and edge guide bearings located along the lower edge of the band. The printer processor circuit board provides the logic control and protection of band overload conditions, and also initiates start up and shut down procedures.

b. Ribbon Drive System. Ribbon drive (fig. 1-5) is controlled by a belt-driven capstan drive roller whose motion is synchronized with character band rotation. The ribbon, which consists of a continuous loop, is pulled past the print station by means of the belt-driven capstan drive roller in conjunction with a counter rotating idler roller. The ribbon drive then refolds the ribbon in fanfold fashion and restores it into position in the ribbon cartridge. The ribbon drive then refolds the ribbon in fanfold fashion and restores it into position in the ribbon cartridge.

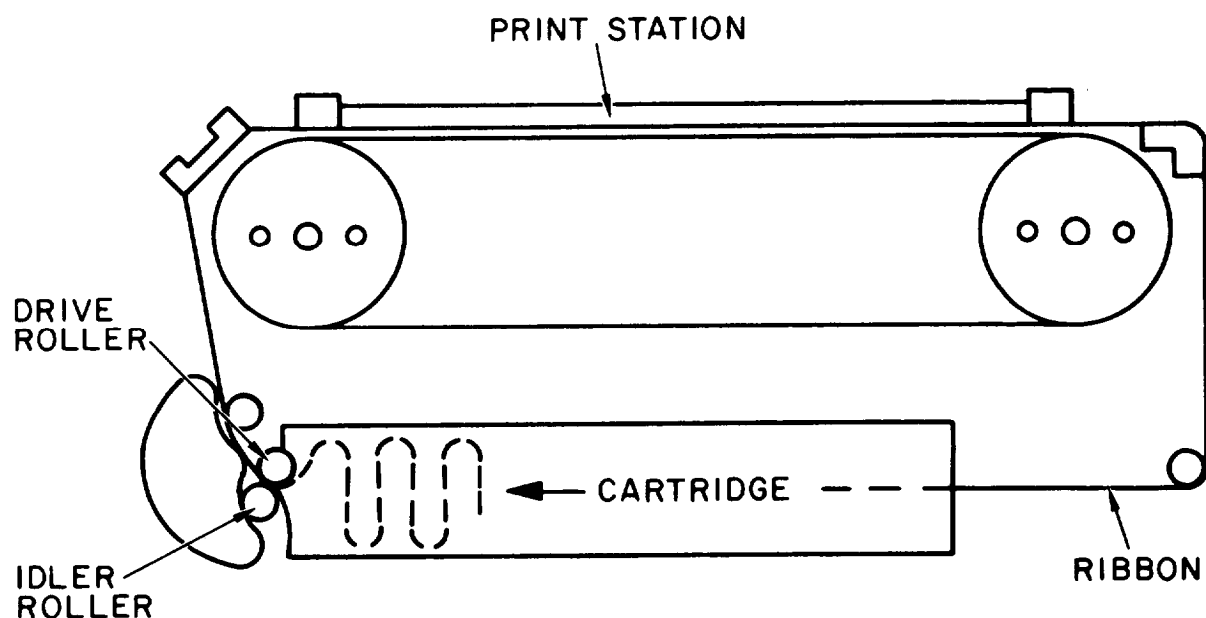

Figure 1-5. Ribbon Drive

Ribbon motion is monitored by a ribbon motion sensor (fig. 1-6) which consists of a rotating magnetic capstan coupled with a hall effect switching device. The ribbon motion sensor is also coupled with a ribbon jam detector switch which will be activated if the ribbon wraps around the ribbon rollers. If ribbon motion stops or a ribbon jam is detected the ribbon motion sensor line is opened to generate a ribbon motion and ribbon jam fault indication.

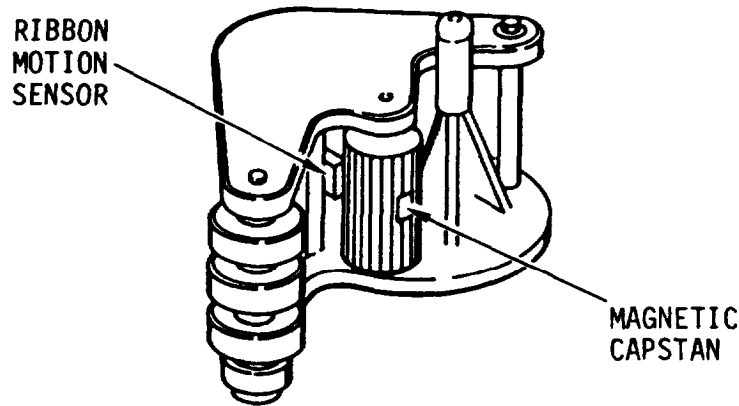

Figure 1-6. Ribbon Motion Sensor

c. Form Movement. Form movement (fig. 1-7) consists of a dual pin feed mechanism driven by a phase controlled motor, which is under processor control. The paper forms are advanced at six or eight lines per inch according to the setting of the 6/8 lines switch on the control panel. The paper forms are also advanced in either single or multiple line rates under system control. Single or multipart forms, which are stowed in the front paper compartment, are fed up through the pressure throat, across the print station and over the two pin feed sprocket assemblies which provide the form drive. The forms are then fed through to the form exit located at the rear section of the print mechanism. Paper tension is provided by three pressure rollers, located at the paper throat, and five adjustable paper puller pressure rollers, located at the rear of the printer.

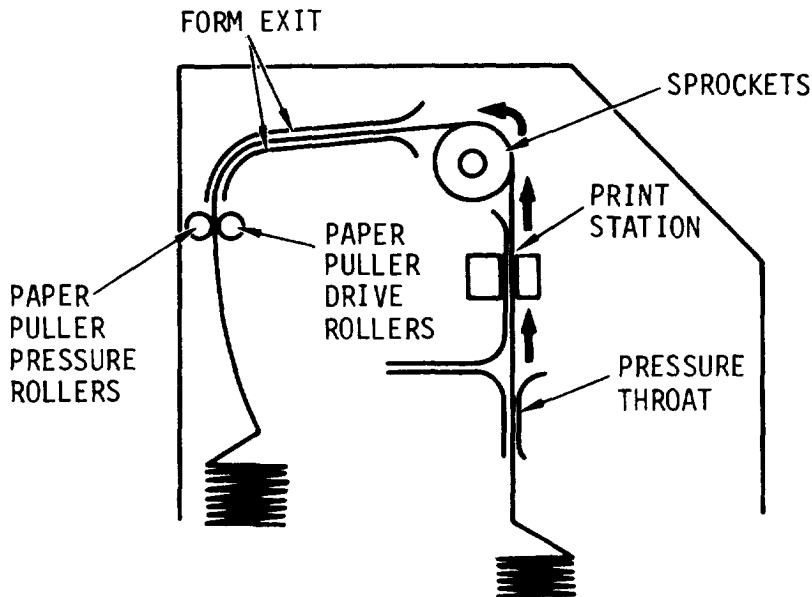

Figure 1-7. Form Movement

Form motion and paper supply are constantly monitored by a paper motion sensor (fig. 1-8) and a paper low switch which when activated will cause an alarm condition and automatically take the printer off line.

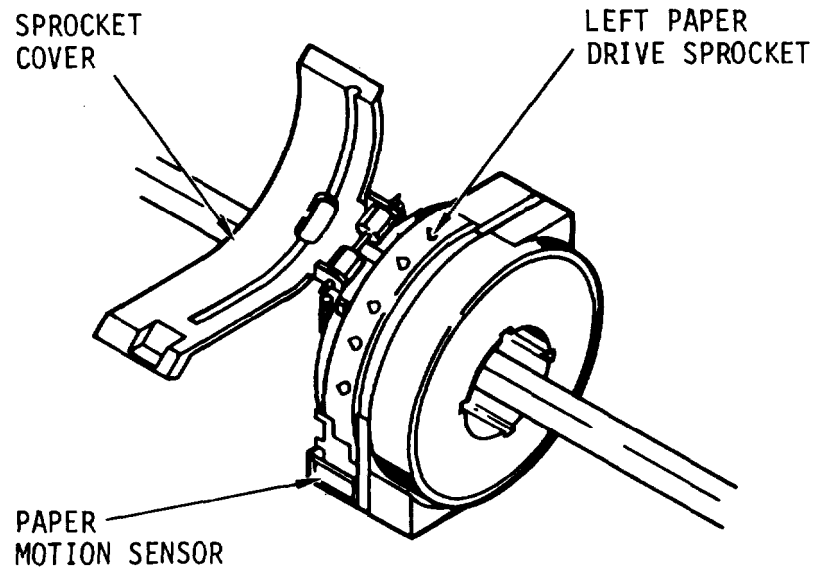

Figure 1-8. Paper Motion Sensor

The printer uses an optical tape reader and punched tape loop to control vertical movement and produce particular print formats. Provision is made for a maximum of 12 user-programmed format channels. These format channels are located on the punched VFU tape (fig. 1-9). Each channel is represented by a numbered vertical column on the punched tape loop and the arrangement of the punched tape loop and the punched holes in the vertical column determines the fixed formats. The tape loop is representative of the paper form used by the printer and contains selectable bit positions for each line of the form. Each tape loop has 12 vertical columns and can be made to produce up to 12 formats. Figure 1-9 illustrates the relationship between the sprocket driven tape and the lines on a representative 66 line print form. Each sprocket hole on the tape represents one line of the form. Therefore, for a standard 11 inch form with 6 lines per inch spacing, 66 sprocket holes represent one form length of the tape.

With the exception of channel 1, the vertical location of punched holes in each channel is determined by user personnel in relation to the print format required. The printer program automatically selects channel 1 when the TOP OF FORM switch is actuated by the operator or when a TOP OF FORM signal code is received from the user system. Normally, as shown in figure 1-9, top of form and bottom of form are the first and last lines of print.

d. Printer Subsystem. The printer subsystem consists of a hammer bank which contains 132 individually controlled hammer actuators. The firing of the hammer actuators are controlled by the circuits on the hammer driver circuit boards. Synchronization of hammer firing or start time of each individual hammer travel is under control of the printer processor circuit board. Mechanical adjustment of each hammer actuator determines the hammer flight time and the time required to dampen its return motion.

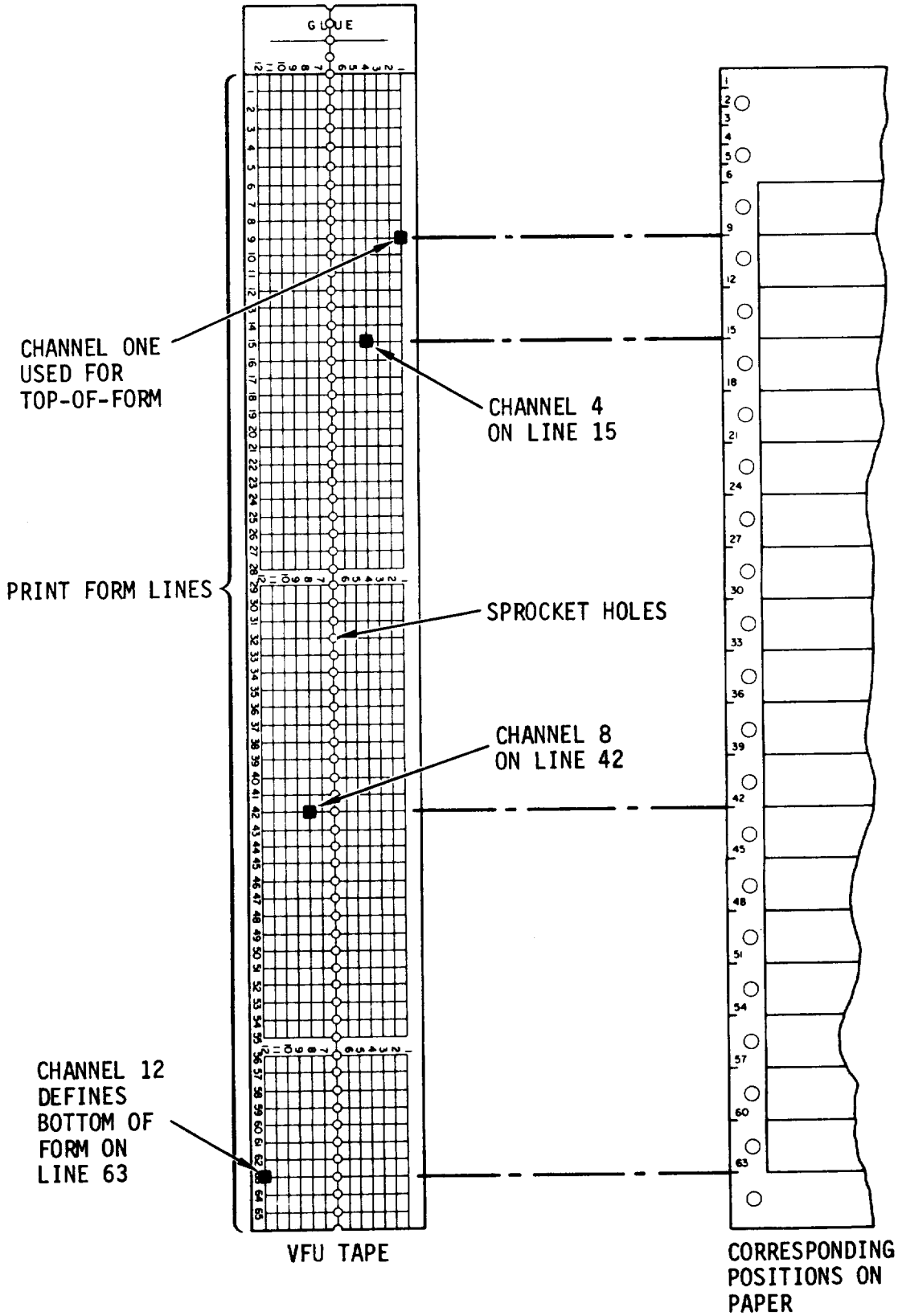

Figure 1-9. Typical VFU Tape Format

f. Power Subsystem. The main printer power supply in conjunction with the power circuit board provides the necessary regulated and unregulated voltages required for system operation. A thermal circuit breaker, part of the main power switch, and fuses F1 thru F3 on the rectifier circuit board provide the overload protection for the power circuitry.

CHAPTER 2 OPERATING INSTRUCTIONS

Index of Operating Procedures

Paragraph No.	Title	Page No.
2-7	Power ON/Power OFF Line Printer	2-9
2-8	Install/Remove Paper	2-11
2-9	Remove/Replace Ribbon Cartridge	2-18
2-10	Remove/Replace Character Band	2-22
2-13	Prepare VFU Punched Tape	2-26
2-14	Install/Remove VFU Tape	2-30
2-15	Self-Test/Operate Line Printer	2-34

Section I. DESCRIPTION AND USE OF OPERATOR'S CONTROLS AND INDICATORS

2-1. CONTROLS AND INDICATORS

The line printer is operated with mechanical and electronic controls.

a. Mechanical Controls. The following mechanical controls are used to prepare the printer for operation:

- Band Release Handle. Used to create and release tension on character band
- Pivot Arm Assembly. Opens for mounting ribbon on drive roller, magnetic capstan, and first ribbon guide
- Band Cover. Opens for access to VFU assembly and character band. Closes for protection against moving character band
- Hammer Bank Latch Handle. Moves upward and downward to release or lock hammer bank in position
- Paper Drive Sprockets. Used to mount and advance pin-feed paper
- Sprocket Covers. Open for mounting paper on sprocket pins. Close to hold paper securely on pins
- Sprocket Locks. Automatically lock sprockets in position. Can be squeezed and unlocked to allow sprockets to slide along drive shaft
- Paper Guides. Can be positioned along drive shaft to provide support for paper

- Vertical Adjust Knob. Used to adjust paper top of form
- Paper Release Lever. Moves up and down to free or lock vertical adjust knob in position
- Paper Puller Pressure Rollers. Can be positioned to create tension on paper as it is pulled across hammer bank assembly

b. Electronic Controls. The following electronic controls are used to prepare and place the printer in on-line or off-line operation:

- POWER ON/OFF Switch. Turns printer on and off
- Vertical Format Unit. Uses operator-installed optical tape to advance paper to top of form and to desired line positions within a form
- Tape Read Request Switch. When pressed (fig. 2-1), VFU tape revolves through tape reader head which reads holes punched in tape
- Control Panel. Contains switches and indicators used to operate the line printer. Part of the control panel is visible (fig. 2-2) and part is hidden under the operator door (fig. 2-3). To access these hidden controls you must open the operator door. These controls should not be used while printer is operating on line under system control

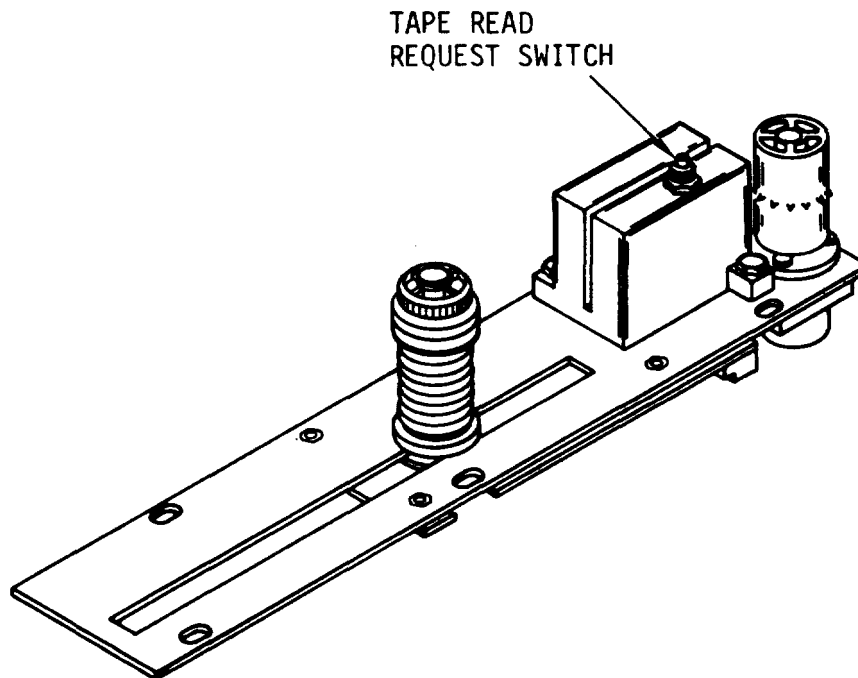
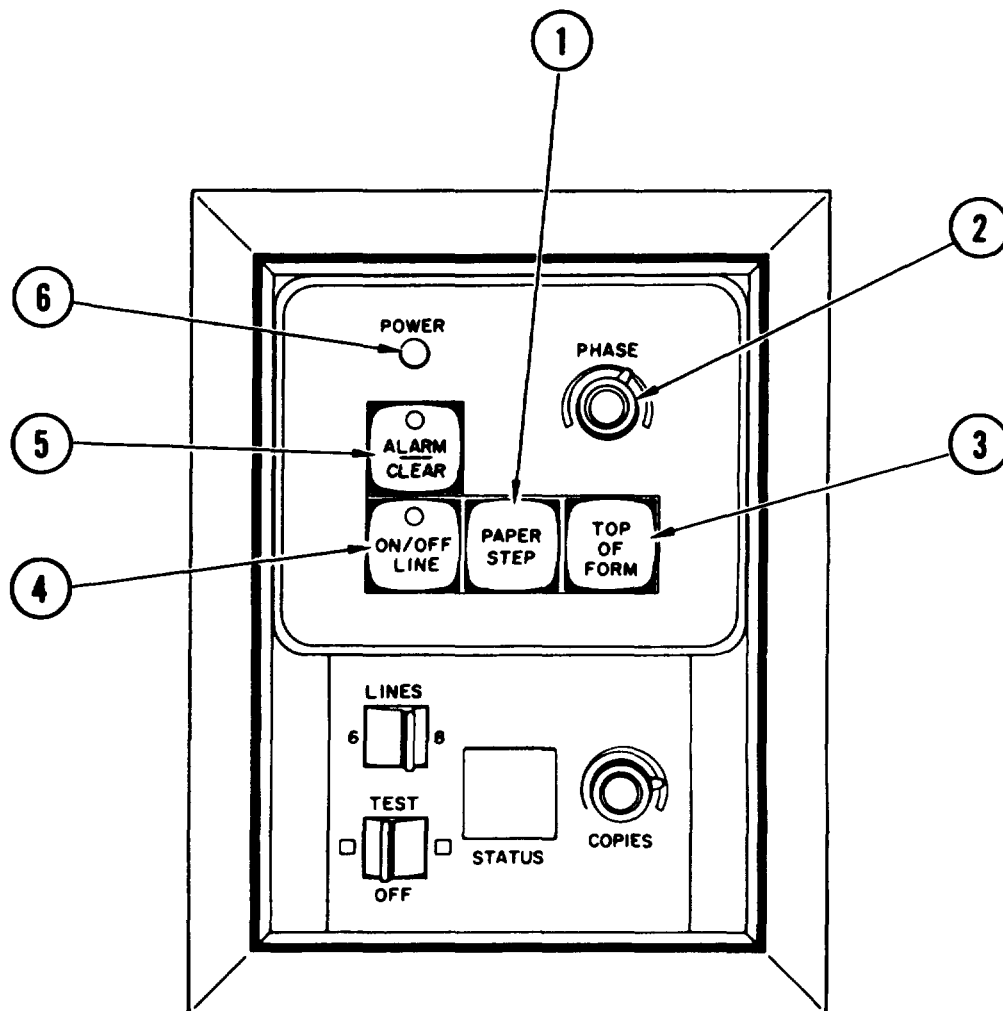
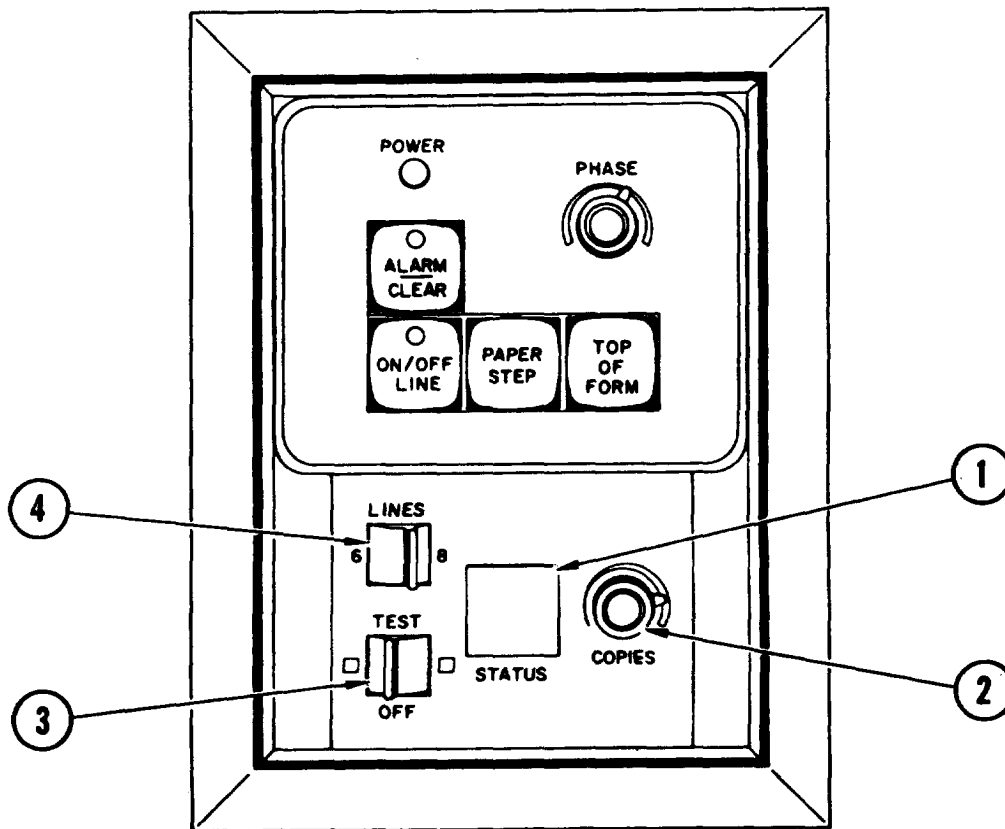

Figure 2-1. VFU Tape Read Request Switch



- ① PAPER STEP Switch - Advances paper one line if pressed when printer is off line. Does not operate when printer is on line.
- ② PHASE Control Knob - Used to maintain equal printing density on left and right side of characters.
- ③ TOP OF FORM Switch - Advances paper to next top of form position if pressed when printer is off line. Does not operate when printer is on line.
- ④ ON/OFF LINE Switch/Indicator - Lights when the printer is on line. Pressing the switch alternately places the printer on line and off line. If the STATUS indicator displays the number 16, the printer has entered the single step mode and the last form is at the print station. Each time the ON/OFF LINE switch is pressed, the printer will print one line until the bottom of form is reached.
- ⑤ ALARM/CLEAR Switch/Indicator - Indicator lights when printer detects fault, and STATUS indicator displays fault code. When pressed, switch clears fault codes in STATUS indicator.
- ⑥ POWER Indicator - Lights when printer is powered ON.

Figure 2-2. Externally Accessible Operator Controls



- ① STATUS Indicator - Displays alphanumeric codes (table 3-1) which indicate operation being performed or fault which caused printer failure.
- ② COPIES Control Knob - Adjusts striking force of print hammers to various thicknesses of paper, from single to six-part copy.
- ③ TEST/OFF Switch - A three-position switch used with the ON/OFF LINE switch to run printer self test. Pressing the ON/OFF LINE switch with the TEST switch in right or left position causes the printer to print at full speed in a sliding or fixed pattern. Moving the TEST switch to center (OFF) position from either right or left position causes the printer to print at half speed in the sliding or fixed pattern. Pressing the ON/OFF LINE switch, then placing the TEST switch in the center (OFF) position terminates the self-test mode.
- ④ 6/8 LINES Switch - Two-position switch used to select either six or eight lines per inch print density when printer is off line.

Figure 2-3. Internally Accessible Operator Controls

Section II. PREVENTIVE MAINTENANCE CHECKS AND SERVICES

2-2. GENERAL

Operator's Preventive Maintenance Checks and Services (PMCS) are the required daily and weekly inspection and care of the equipment necessary to keep it in good operating condition. PMCS shall be done before (B) operation, during (D) operation and after (A) operation. Other checks and services are done on a weekly (W) or monthly (M) cycle.

NOTE

Always observe all WARNINGS and CAUTIONS when you perform the PMCS procedures.

- a. Before operation. Do your before (B) PMCS to be sure that the equipment is ready for operation.
- b. During operation. Do your during (D) PMCS to be sure that the equipment is operating properly.
- c. After operation. Do your after (A) PMCS so that the equipment will be ready for future operation.
- d. If your equipment fails to operate. Refer to chapter 3 for troubleshooting procedures. Report any deficiency on DA Form 2404. See TM 38-750.

2-3. PMCS PROCEDURES

PMCS procedures are done at fixed intervals for the following purposes:

- Make sure that the equipment is operable
- Prevent equipment problems in future operation
- Identify and resolve minor problems in the equipment before they become major problems
- Scheduled cleaning of the equipment

a. PMCS Table. The PMCS procedures are contained in table 2-1. This information is given by item number, interval, item inspected, procedure and criteria for rejection. An explanation of the contents of each column is given below.

(1) Item Number Column. The checks and services are numbered in chronological order. The numbers in this column shall be used in the TM Item No. column of DA Form 2404, Equipment Inspection and Maintenance Worksheet, in recording results of PMCS.

(2) Interval Column. This column identifies the interval at which the check or service is performed. Only those columns are used which are pertinent to the equipment.

(3) Item To Be Inspected Column. The equipment or portion of the equipment being checked or serviced is listed in this column.

(4) Procedures Column. This column contains the check or service procedure.

(5) Equipment Is Not Ready/Available If: Column. The reason why an equipment will be classified as unable to perform its mission will be given in this column. An entry in this column will:

(a) Identify conditions that make the equipment not ready/available for readiness reporting purposes.

(b) Deny use of the equipment until corrective maintenance has been performed.

b. Routine Checks. Checks like equipment inventory, cleaning, dusting, washing, checking for frayed cables, storing items not in use, covering unused receptacles and checking for loose nuts and bolts are not listed in your PMCS. They are things you should do anytime you see they must be done. If you find a routine check like one of these listed in your PMCS, it was listed because other operators reported problems with this item.

Table 2-1. Preventive Maintenance Checks and Services

NOTE

If the equipment must be kept in continuous operation, check and service only those items that can be checked and serviced without disturbing operation. Make the complete checks and services when the equipment can be shut down.

NOTE : Within designated interval, these checks are to be done in the order listed.

B = Before

W = Weekly

M = Monthly

Perform weekly as well as before PMCS if:

(1) You are the assigned operator and have not operated the equipment since the last weekly.

(2) You are operating the equipment for the first time.

Table 2-1. Preventive Maintenance Checks and Services -- Continued

Item No.	Interval			Item to be Inspected	Procedures Check for and have repaired or adjusted as necessary	Equipment is not ready/available if:
	B	W	M			
1	•			Character Band	Check position of character band. Adjust if necessary.	Self test printout shows missing characters or lines. Mask is cracked or broken.
2	•			Line Printer	Check operation by running self test. Clean exterior.	
3		•		Character Band and Pulleys	Inspect character band and pulleys for ribbon lint buildup. Clean if necessary.	
4		•		Ribbon Mask and Ribbon	Check ribbon mask and ribbon for signs of wear or breaks.	
5		•		Ribbon Motion Sensor	Check for ribbon lint and paper dust buildup. Clean if necessary.	
6		•		Paper Motion Sensor	Check for ribbon lint and paper dust. Clean if necessary.	

Section III. OPERATION UNDER USUAL CONDITIONS

2-4. ASSEMBLY AND PREPARATION FOR USE

See your system manual for information on location of the ac power source. Before you insert the ac power plug into the power source, check that the ON/OFF power switch is in the OFF position.

Make sure these items are installed before operation.

- Ribbon cartridge
- Character band
- Paper
- VFU tape

2-5. INITIAL ADJUSTMENTS, DAILY CHECKS, AND SELF-TEST

Perform the following initial adjustments, daily checks, and self-test before start up.

WARNING

Top edges of character band are sharp. Avoid contact.

- a. Press 6/8 LINES switch for desired lines per inch.
- b. Check paper supply. Install if necessary.
- c. Make paper TOP OF FORM and character alignment settings.
- d. Check that sprockets are locked into position.
- e. Check that VFU tape is mounted and read by tape reader.
- f. Check that printer is free from ribbon and paper dust. If necessary, lift top cover and clean printer with vacuum.
- g. Check inking condition of ribbon. Run self-test. If print is light, adjust PHASE or COPIES control or install new ribbon cartridge. If print is still too light tell your supervisor maintenance is required.

2-6. OPERATING PROCEDURES

The operating procedures which follow enable you to prepare the line printer for operation; operate, remove from operation, and place in standby condition or shutdown status.

2-7. POWER ON/POWER OFF LINE PRINTER

Power on

NOTE

In some installations printer must be pulled away from wall before POWER switch can be set to ON. See your system manual.

1. Set POWER switch to ON at rear of printer.

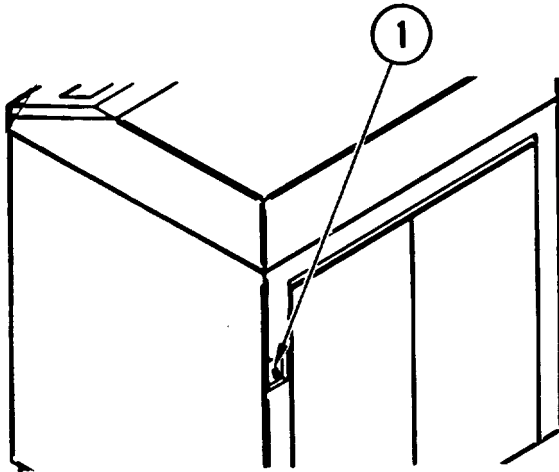

2. Check that POWER indicator is lit. If not, troubleshoot printer (table 3-1).
3. After three seconds, check that indicator on ALARM/CLEAR switch goes out. If not, troubleshoot printer (table 3-1).

NOTE

In some installations printer must be pushed back against wall after POWER switch is set to ON. See your system manual.

Power off

1. Make sure printer has completed all printing operations.
2. Press ON/OFF LINE switch and wait for indicator to go out.

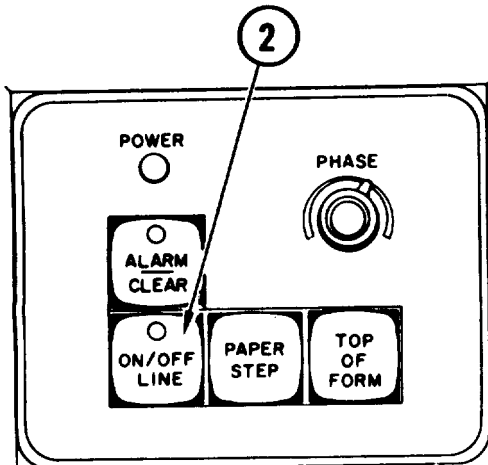
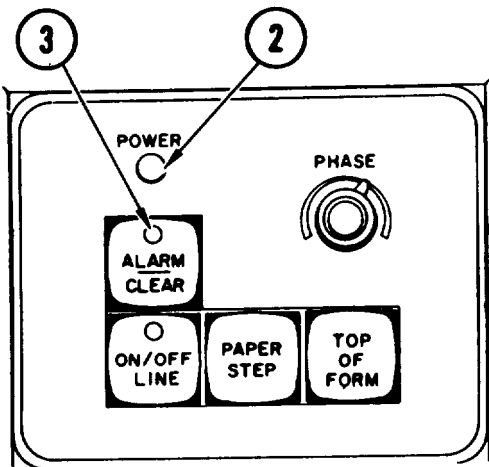

2-7. POWER ON/POWER OFF LINE PRINTER (CONT)

NOTE

In some installations printer must be pulled away from wall before POWER switch can be set to OFF. See your system manual.

3. Set POWER switch to OFF at rear of printer.

NOTE

In some installations printer must be pushed back against wall after POWER switch is set to OFF. See your system manual.

4. Check that POWER indicator on control panel goes out.

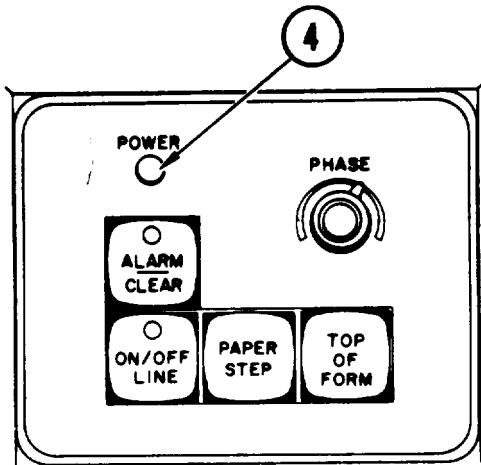
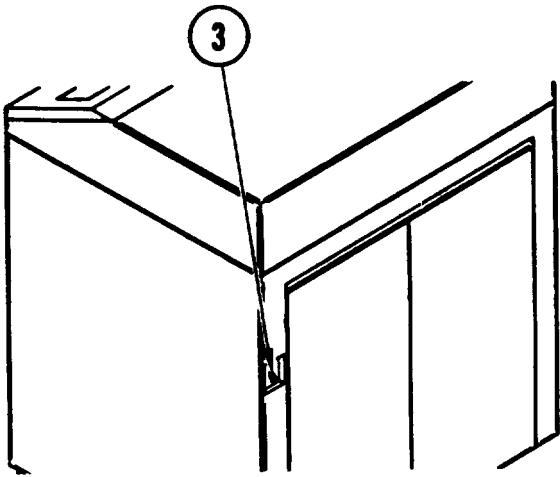

2-8. INSTALL/REMOVE PAPER

INITIAL SETUP

Supplies

- Pin-feed (fanfold) paper

Install

1. Power ON printer (para 2-7).
2. Open operator door.

WARNING

Stay clear of character band until it stops moving. Otherwise, injury may result.

3. Lift hammer bank latch handle to open hammer bank.

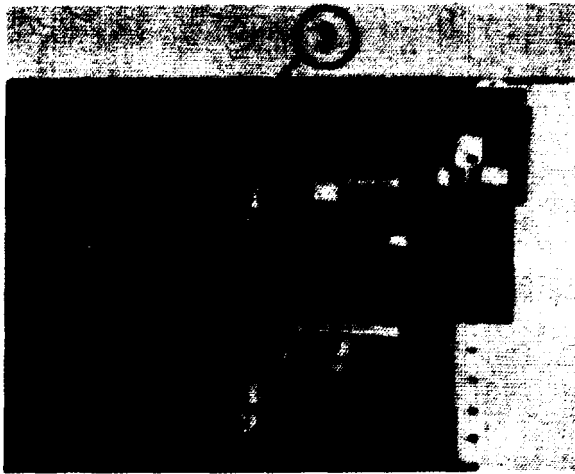

4. Squeeze sprocket locks. Then slide sprocket assemblies along drive shaft to approximate paper width.



2-8. INSTALL/REMOVE PAPER (CONT)

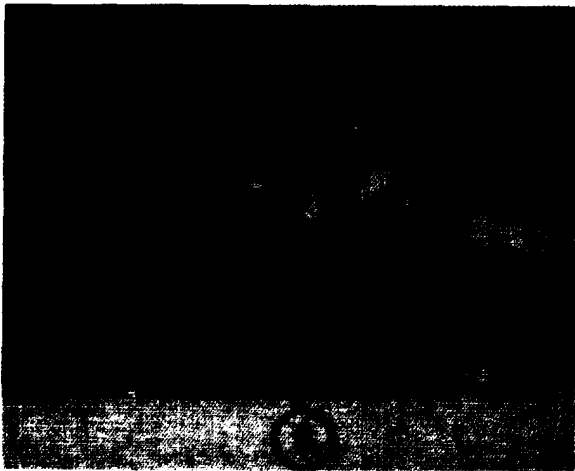

5. Position paper support guides equally between sprocket assemblies.

6. Open both sprocket covers.

NOTE

In some installations printer must be pulled away from wall before acoustic cabinet rear doors can be opened. See your system manual for access instructions.

7. Open acoustic cabinet rear doors.
8. Check that paper shelf is in position on paper shelf rails.

CAUTION

Be careful not to place too much tension on paper. Otherwise, paper will jam and tear.

9. Snap down the following paper puller rollers according to paper thickness used:

- Single part paper-two outside rollers
- Two to three part paper - middle and two outside rollers
- Four to six part paper-all five rollers

10. Check that paper guides are in place.

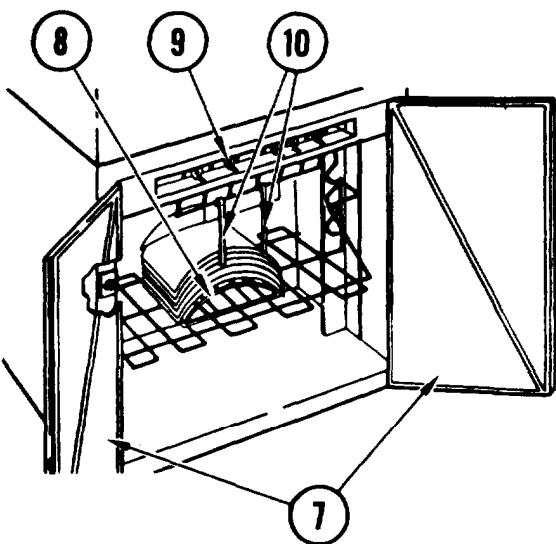

2-8. INSTALL/REMOVE PAPER (CONT)

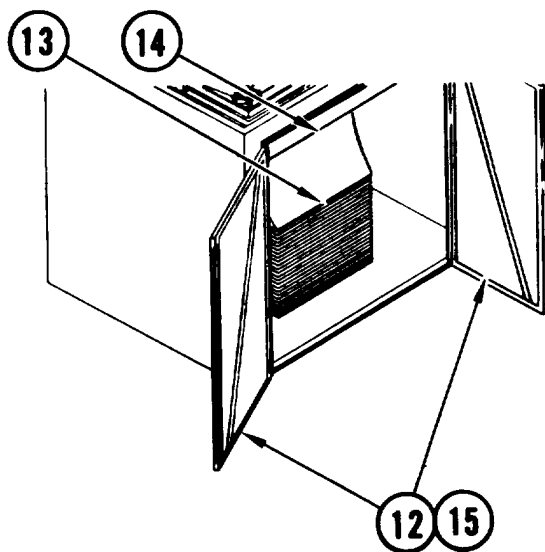

NOTE

In some installations printer must be pushed back against wall after acoustic cabinet rear doors are closed. See your system manual.

11. Close acoustic cabinet rear doors.
12. Open acoustic cabinet front doors.
13. Install paper supply.
14. Feed paper up through paper throat.
15. Close acoustic cabinet front doors.

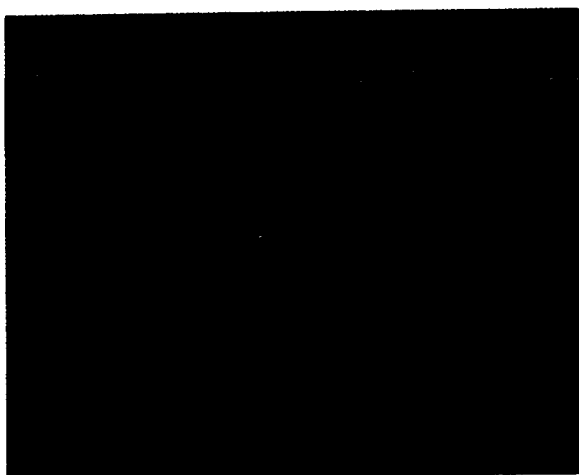

16. Pull paper up through paper throat until it extends just half way over sprockets.

CAUTION

Paper will tear if not evenly alined on both sprockets with moderate tension on paper.

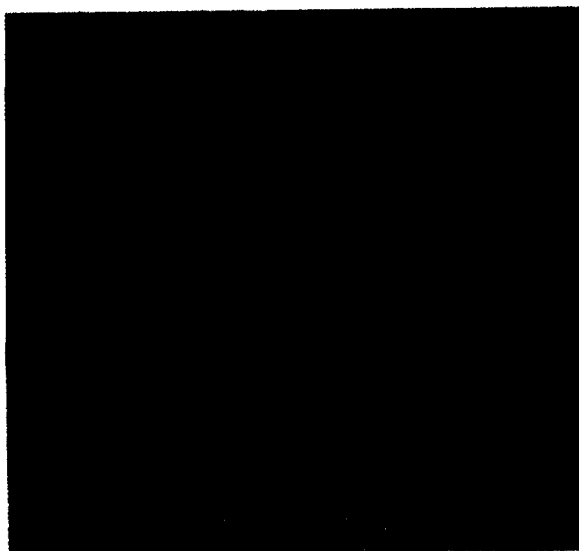

17. Aline and mount paper on both sprockets. Close sprocket covers.
18. Check paper tension. Squeeze sprocket locks and adjust sprockets as required for moderate paper tension.

2-8. INSTALL/REMOVE PAPER (CONT)

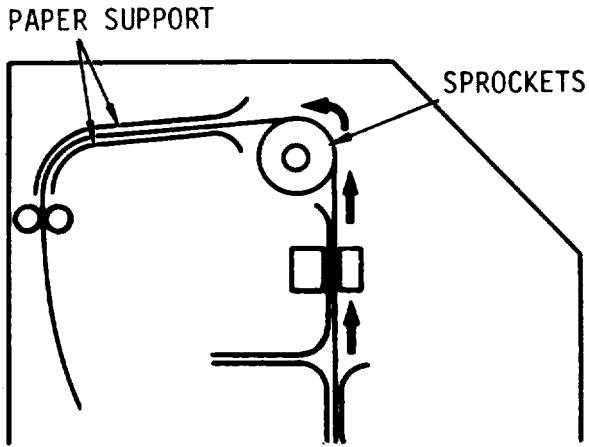

19. Press PAPER STEP switch on control panel until paper enters paper support, as shown.

20. Press TOP OF FORM switch on control panel.

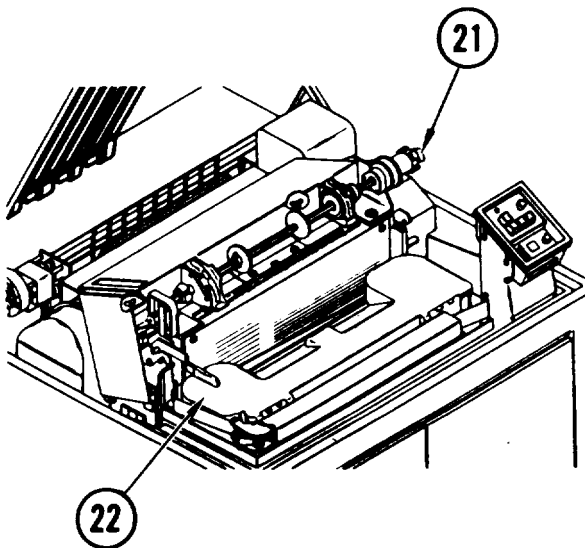

21. Position paper release lever so that red marker is visible.

22. Open band cover.

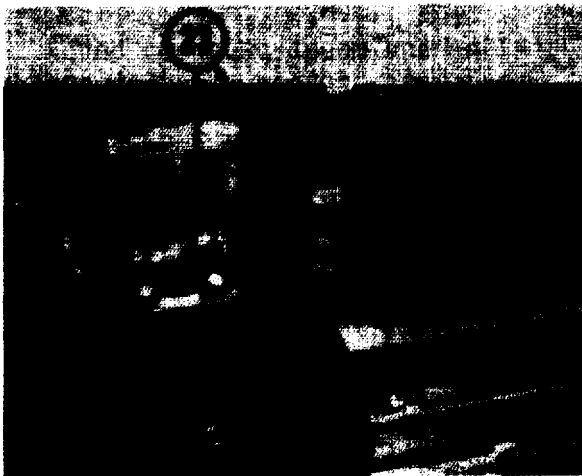

23. Locate 6 LPI and 8 LPI top of form index markings on left and right sides of hammer bank mask.

24. Check the way top of form is set:

- Top of form is the same as the first print line on the paper form
- In the example shown, the desired first print line is line six, so the perforation is set at number six

2-8. INSTALL/REMOVE PAPER (CONT)

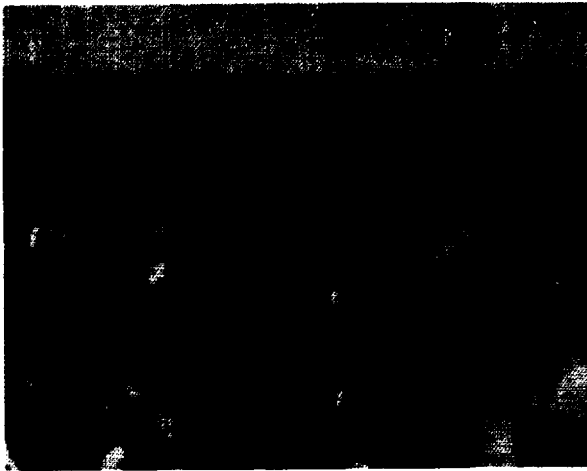

25. Rotate vertical adjust knob and set paper perforation at desired top of form index marking.

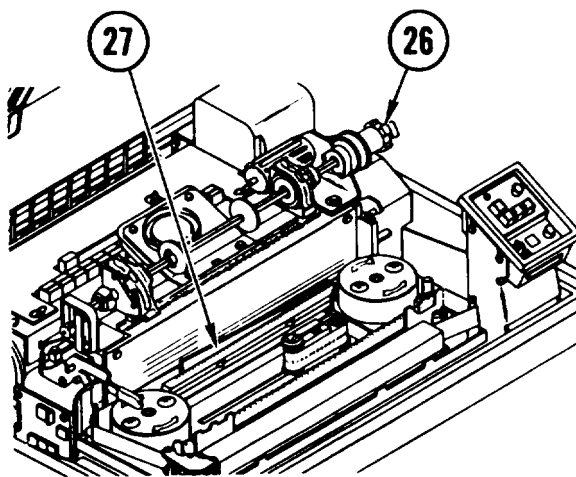

26. Position paper release lever so red marker is not visible.
27. Locate forms alinement decal attached to top of platen.

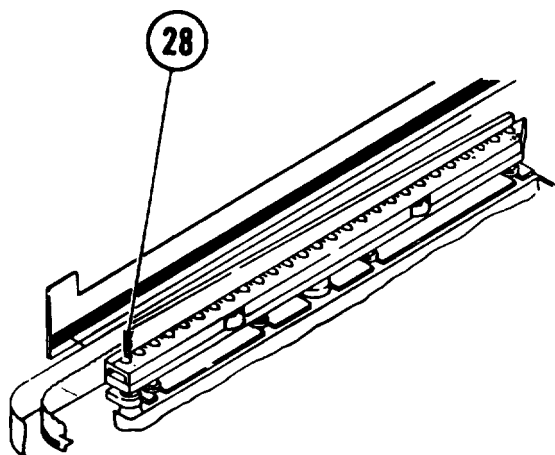

28. Squeeze both sprocket locks and slide sprockets until desired location of first print column on paper is alined with column 1 marker on forms alinement decal.

2-8. INSTALL/REMOVE PAPER (CONT)

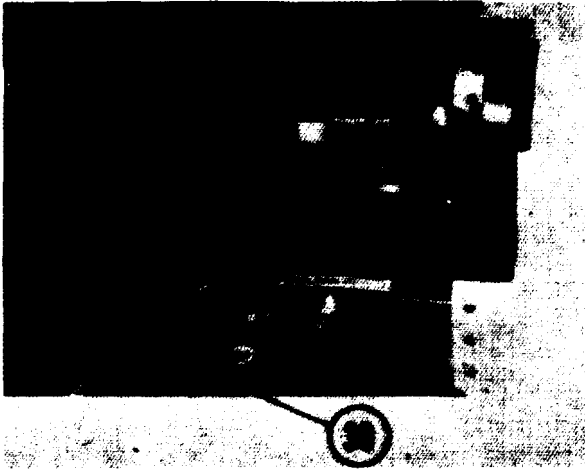

29. Close band cover.
30. Lower hammer bank latch handle and press into locked position.
31. Close operator door.
32. Press ALARM/CLEAR switch on control panel.

Remove

1. There are two conditions under which paper may be removed.
 - If a low paper condition exists, go to step 6
 - If a low paper condition does not exist, go to step 2
2. Open front doors.
3. Tear off paper at perforation.
4. Close front doors.
5. Power ON printer (para 2-7).
6. Press TOP OF FORM switch repeatedly until all printed forms are stacked and folded in rear paper compartment.

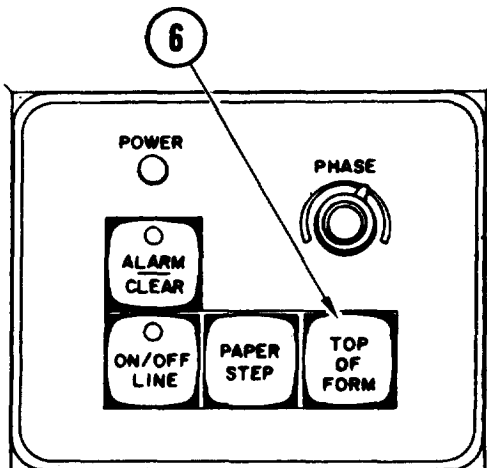

NOTE

In some installations printer must be pulled away from wall so acoustic cabinet rear doors can be opened. See your system manual for access instructions.

2-8. INSTALL/REMOVE PAPER (CONT)

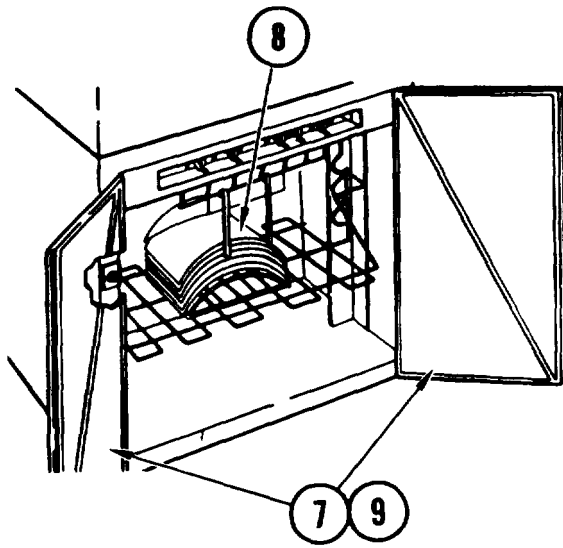

7. Open acoustic cabinet rear doors.
8. Remove paper.

NOTE

In some installations printer must be pushed back against wall after acoustic cabinet rear doors are closed. See your system manual.

9. Close acoustic cabinet rear doors.
10. Power OFF printer (para 2-7).

2-9. REMOVE/REPLACE RIBBON CARTRIDGE



Remove

1. Power OFF printer (para 2-7).
2. Open operator door.
3. Lift up hammer bank latch handle to open hammer bank.



4. Open pivot arm assembly.



5. Slide ribbon carriage 1.5 in. (4 cm) in direction shown.

2-9. REMOVE/REPLACE RIBBON CARTRIDGE (CONT)



6. Remove ribbon cartridge from printer.

Replace

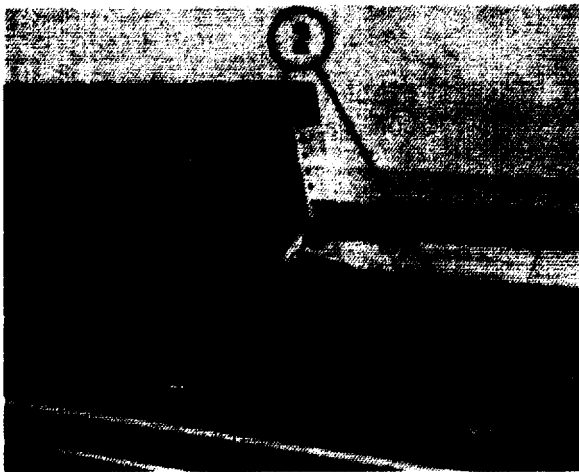

1. Open operator door.
2. Place cartridge on metal locating buttons so that indented end points left.

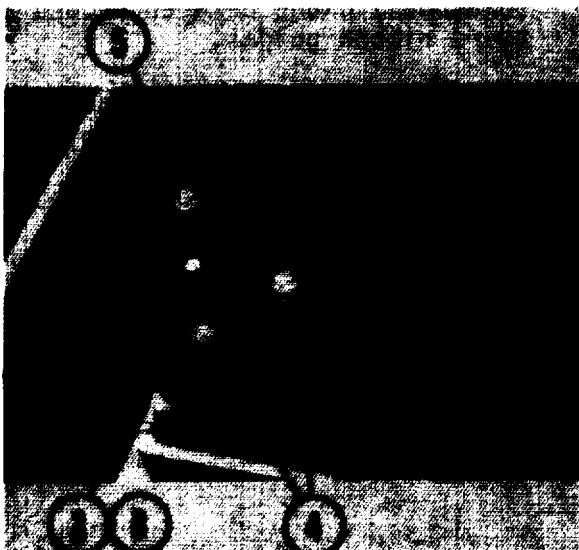

3. Open pivot arm assembly.
4. Thread ribbon between rollers.
5. Guide ribbon around first ribbon guide.
6. Pull ribbon slack away from ribbon cartridge.
7. Slide cartridge to the left until it locks in place.
8. Close pivot arm assembly.

2-9. REMOVE/REPLACE RIBBON CARTRIDGE (CONT)

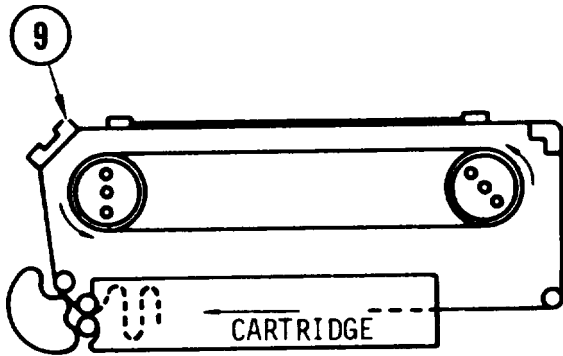

9. Guide ribbon around second ribbon guide.

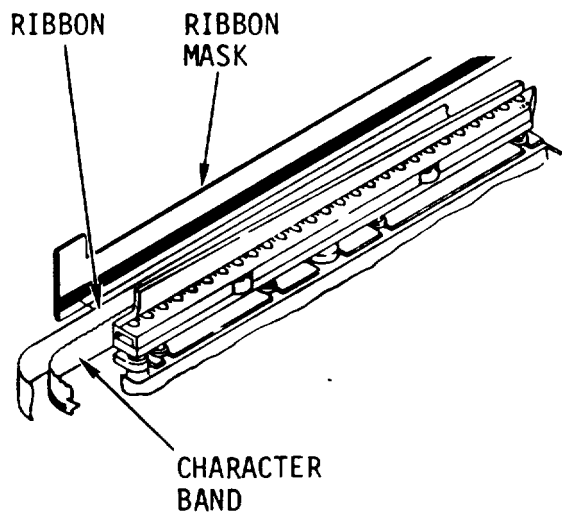

10. Insert ribbon between character band and ribbon mask, as shown.

NOTE

Ribbon moves in a top/down (diagonal) plane between second and third ribbon guides.

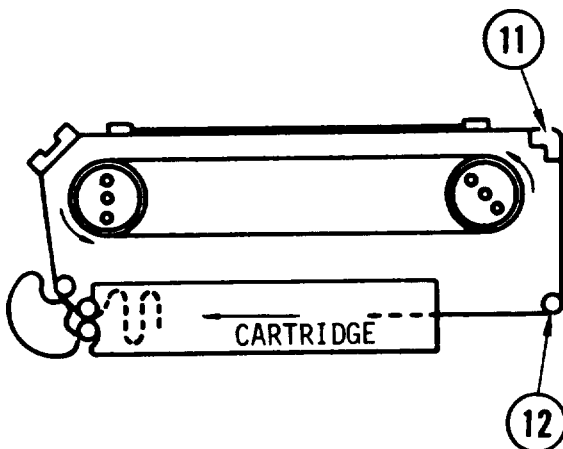

11. Guide ribbon around base and under upper lip of third ribbon guide.
12. Guide ribbon around fourth ribbon guide.

2-9. REMOVE/REPLACE RIBBON CARTRIDGE (CONT)

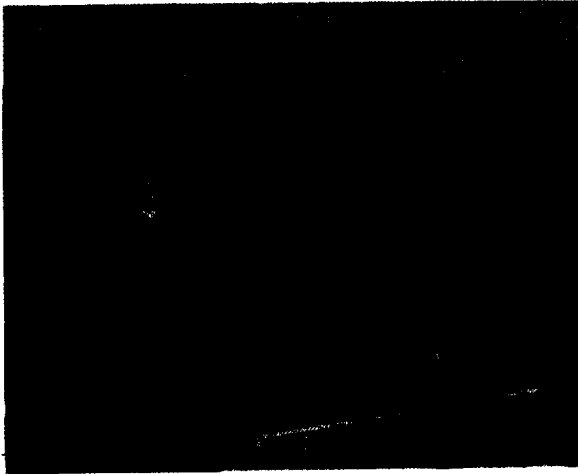

13. Open band cover and rotate either pulley in direction shown to take up ribbon slack.
14. Close band cover.
15. Power ON printer (para 2-7).

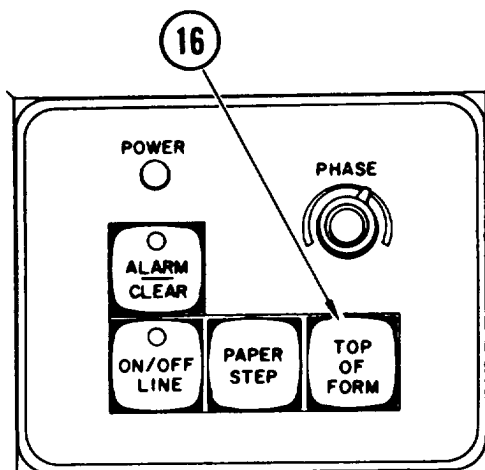

16. Press TOP OF FORM switch,
17. Reset top of form setting (para 2-8, Install, steps 21-26 and 29-31).

2-10. REMOVE/REPLACE CHARACTER BAND

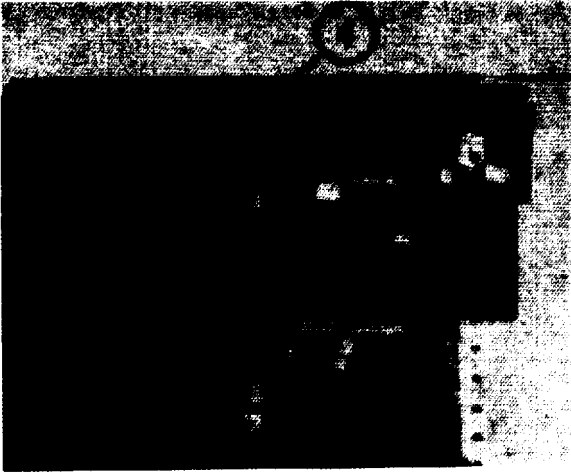

Remove

1. Power OFF printer (para 2-7).
2. Pull ac plug from outlet.
3. Open operator door.
4. Lift up hammer bank latch handle to open hammer bank.
5. Remove ribbon cartridge (para 2-9, Remove, steps 4-6).
6. Open band cover.

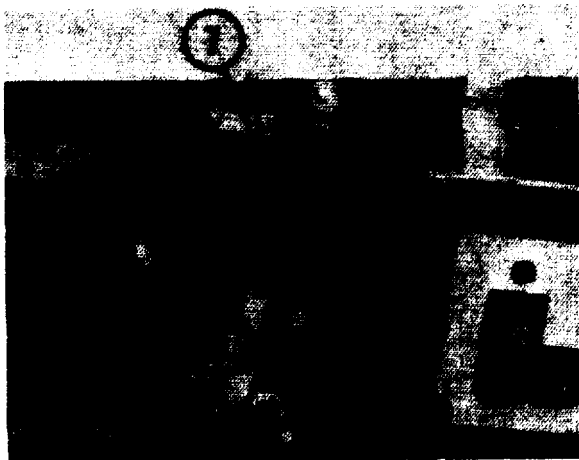

7. Move band release handle toward rear of printer, as shown.

WARNING

Top edges of band are sharp. Avoid contact.

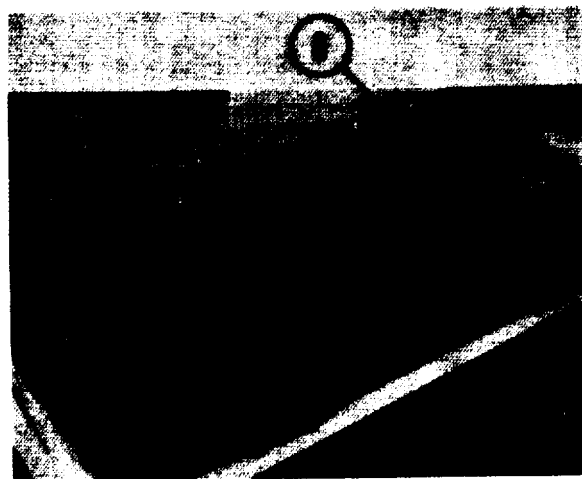

8. While holding band, carefully, lift band from right band pulley.

2-10. REMOVE/REPLACE CHARACTER BAND (CONT)

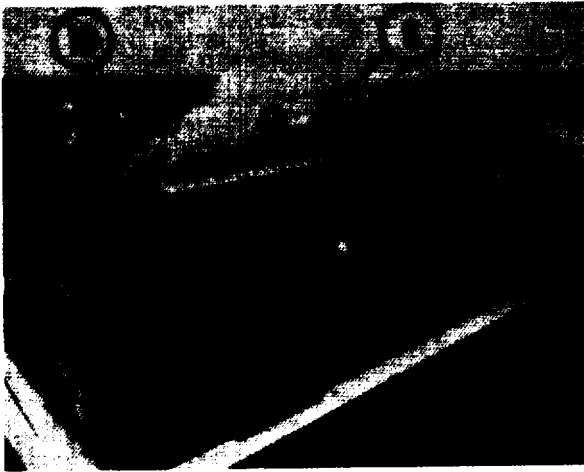

CAUTION

Do not bend character band smaller than diameter of band pulleys.

9. Squeeze band together at center.
10. Lift band off left band pulley. Lift band out of printer.

Replace

WARNING

Top edges of band are sharp. Avoid contact.

1. Hold character band with scalloped edges facing up.
2. Place band around left band pulley.

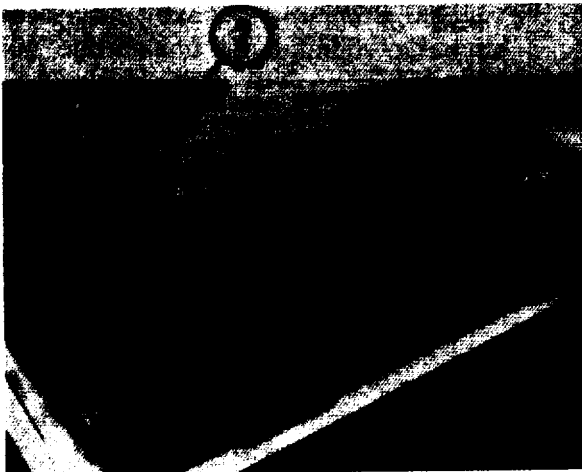

CAUTION

Make sure band is placed between ribbon mask and platen. Otherwise, mask can be damaged.

3. Carefully insert band between ribbon mask and platen, as shown.

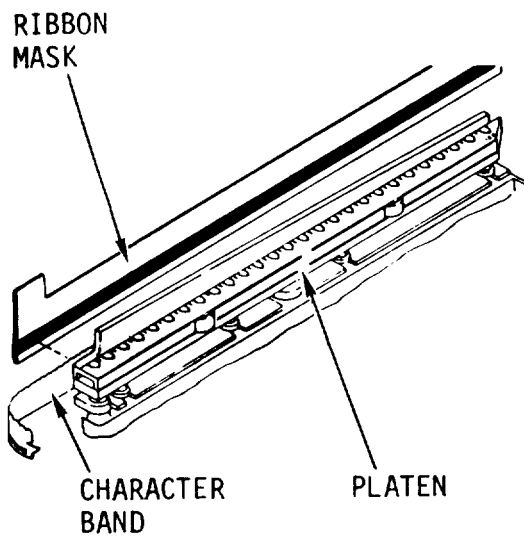

2-10. REMOVE/REPLACE CHARACTER BAND (CONT)

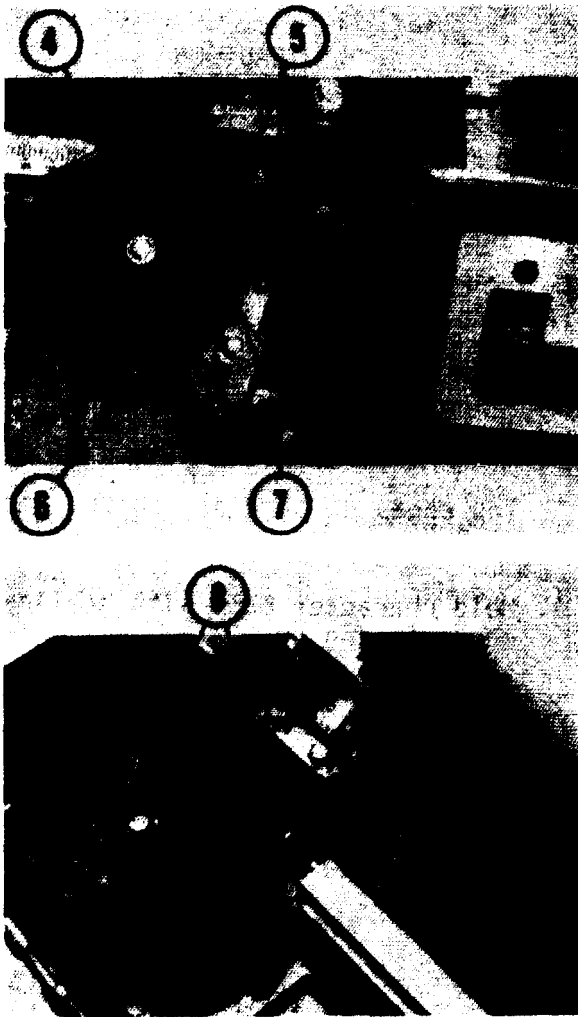

4. Slide band over right band pulley.
5. Position band between band transducer and pulley.
6. Move band down until bottom edge of band rests on edge guide bearing next to each pulley.
 - Right edge guide bearing is located in front of pulley
 - Left edge guide bearing is located at rear of pulley
7. Move band release handle toward front of printer, as shown.
8. While spinning either pulley in direction shown, observe movement of character band over both edge guide bearings.
 - If character band touches, and rides smoothly and evenly over both edge guide bearings, go to step 9
 - If character band does not touch one or both edge guide bearings, remove band and repeat steps 1 thru 7. If problem remains, notify your supervisor that maintenance is required
 - If character band rides unevenly or roughly over one or both edge guide bearings, remove band and repeat steps 1 thru 7. If problem remains, notify supervisor that maintenance is required
9. Close band cover.
10. Replace ribbon cartridge (para 2-9, Replace, steps 2-14).
11. Lower hammer bank latch handle and press into locked position.
12. Push ac plug into outlet.
13. Run self test (para 2-15, steps 5-35).

2-11. OPERATION OF AUXILIARY EQUIPMENT

A manual tape punch device is available as auxiliary equipment to prepare punched paper tape for use in the vertical format unit (VFU).

a. 12 Channel Tape Punch. This device (para 2-13) is fitted with punch, sprocket wheel, tape control knob, line selector, holddown arms, and stabilizing pins for mounting and punching a 12 channel VFU tape.

b. 12 Channel Paper Tape. Paper tape (fig. 1-9) consists of 12 vertically spaced channels divided by prepunched sprocket holes and containing adhesive surface at one end for making the VFU tape loop.

2-12. PUNCHING VFU TAPE

To punch a VFU tape, it is necessary to know tape length and selection of channel punches.

a. VFU Tape Length. The VFU tape length is measured against the VFU tape loop. Each VFU tape loop is as long as the paper form or a multiple thereof. Maximum tape length is 144 lines (24 in. at 6 lpi and 18 in. at 8 lpi). Minimum tape length is 36 lines (6.0 in. at 6 lpi and 4.5 in. at 8 lpi).

b. Selection of Channel Punches. Channels one through twelve may be punched on the VFU tape to enable the printer to move the paper form to the following positions:

(1) Top of Form - Each tape loop should have only one hole punched in channel 1 on the line corresponding to the desired paper top of form (TOF).

(2) Bottom of Form - Each tape loop should have one hole punched in channel 2, 8, 11 or 12 on the line corresponding to the desired paper bottom of form (BOF) based on the setting of switches S3-1 thru S3-3 on the interface board. (See your system manual for switch settings.)

(3) Print Positions - Depending upon the channel used for punching bottom of form hole, each tape loop may have one hole punched in channels 2 thru 11 on the line corresponding to the desired print positions. For example, in the sample VFU tape (fig. 1-9) channel 4 is punched for print position on line 15, and channel 8 is punched for print position on line 42. It is possible to punch channel 4 on lines 15 and 42 and leave channel 8 free for other forms. In this way, multiple forms may be punched onto one tape if the repetition of the format pattern is identical to all other format patterns (TOF, BOF, print position selection) on the tape.

Since the VFU tape is calibrated in lines (not inches), a given tape will yield different dimensional formats for 6 or 8 lpi.

2-13. PREPARE VFU PUNCHED TAPE

INITIAL SETUP

Common Tools

- Scissors
- Ruler

Special Tools

- 12 channel tape punch

Materials/Spare Parts

- Pen or pencil
- Glue

Supplies

- 12 channel paper tape

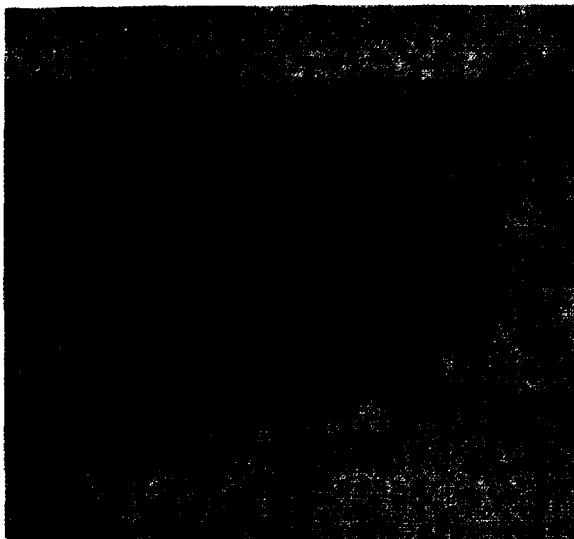

1. Set selector to 6 or 8 lines per inch.
2. Place punch in the stored position marked "S".
3. Lift holddown arms.

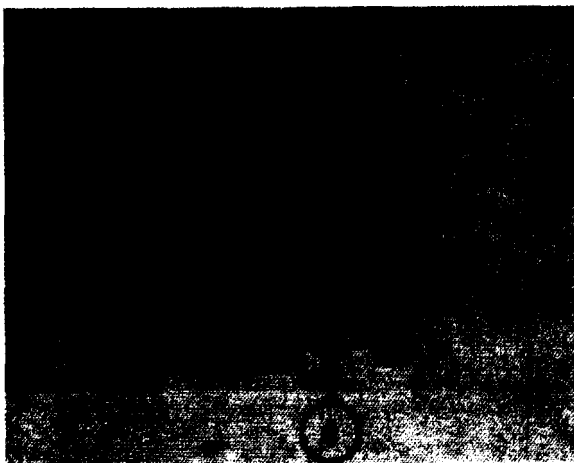

4. Rotate tape control knob until white dot on sprocket is centered in slot.

2-13. PREPARE VFU PUNCHED TAPE (CONT)

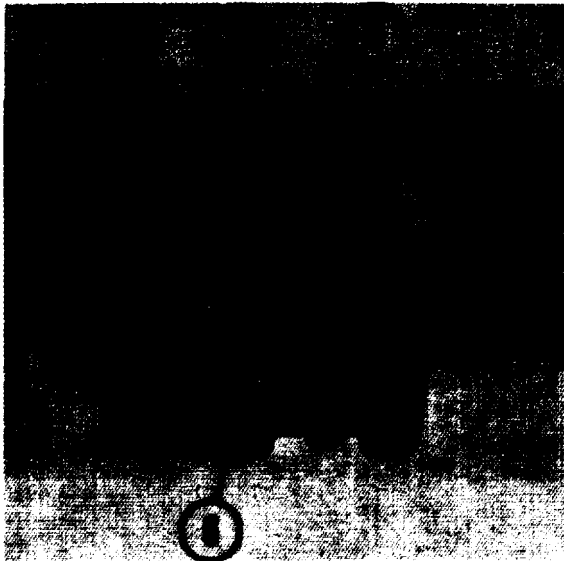

5. Place tape on sprocket teeth.
6. Make sure one of the solid vertical lines on the tape is in line with the registration mark on the front of the punch.
7. Lower holddown arms.

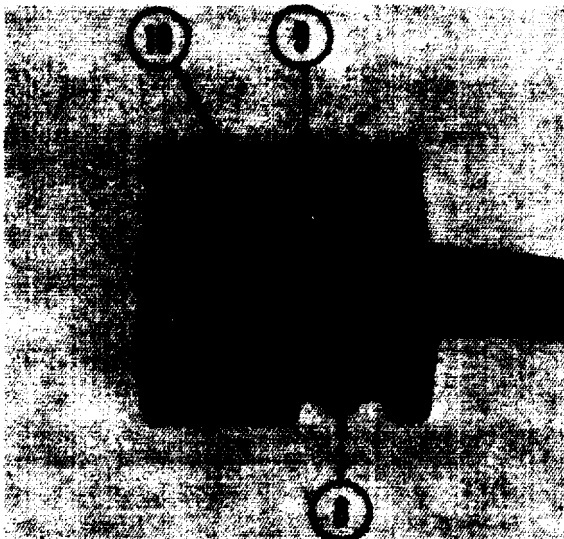

8. Rotating tape control knob, move tape to the desired line.
9. Using numbered slots for direction, position punch at the desired channel.
10. Press punch button firmly.
11. Repeat steps 8 thru 10 to punch any other VFU tape holes.

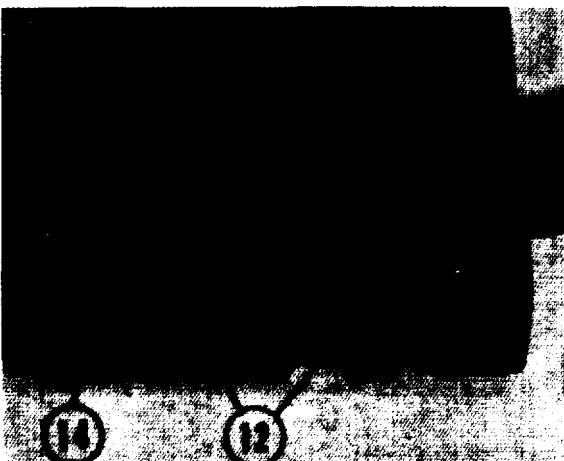

12. Lift holddown arms.
13. Move punch to "S" position.
14. Remove VFU tape from tape punch.

2-13. PREPARE VFU PUNCHED TAPE (CONT)



NOTE

Tape must be cut so that after being spliced, the loop length will be exactly equal to the form length or a multiple of the form length.

15. Using scissors, cut tape to desired length along index line through center of round sprocket hole, as shown.

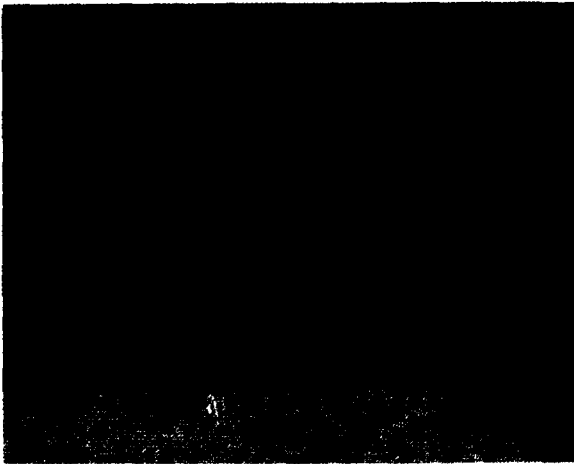

16. Slide tape under punch, as shown.

17. Position tape on pins, as shown.

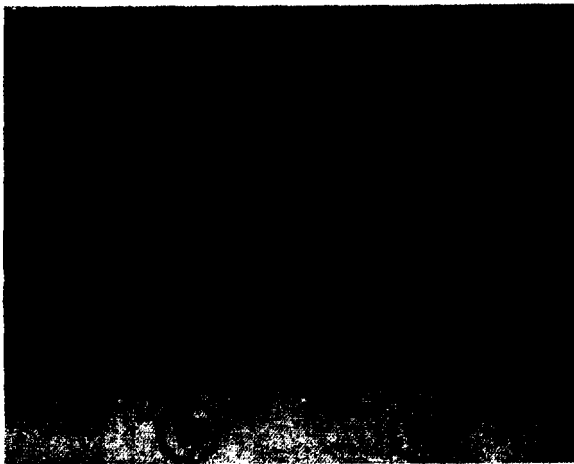

18. Lower right holddown arm, as shown.

19. Peel off protective backing from tape. If there is no protective backing, apply a light coating of glue.

2-13. PREPARE VFU PUNCHED TAPE (CONT)

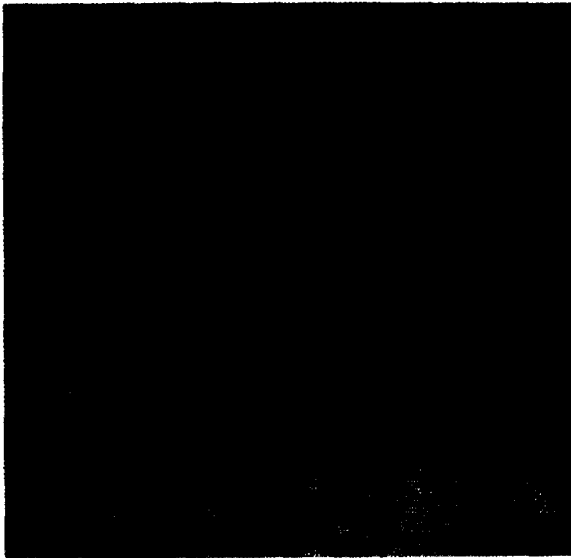

20. Aline cut end of tape with the zero (0) reference line at beginning of tape. Do not press down.
21. Make sure three sprocket holes at cut end of tape are in position over pins.



22. Press firmly to bond tape ends together.
23. Lift right holddown arm, as shown.

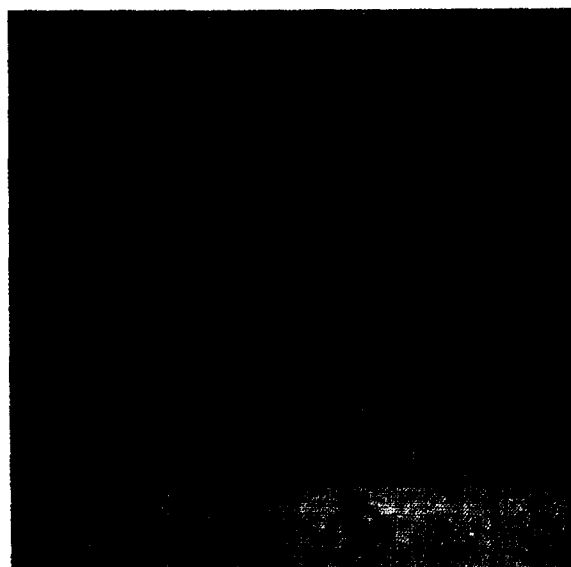

24. Lift tape off pins.
25. Slide tape out from under punch. Lift off tape.
26. Press down with fingers on bonded area of tape a few times. Make sure edges are evenly bonded.

NOTE

Tape is not harmed by wrinkles that may develop when tape is turned printed side out.

27. Turn tape printed side out.

2-14. INSTALL/REMOVE VFU TAPE

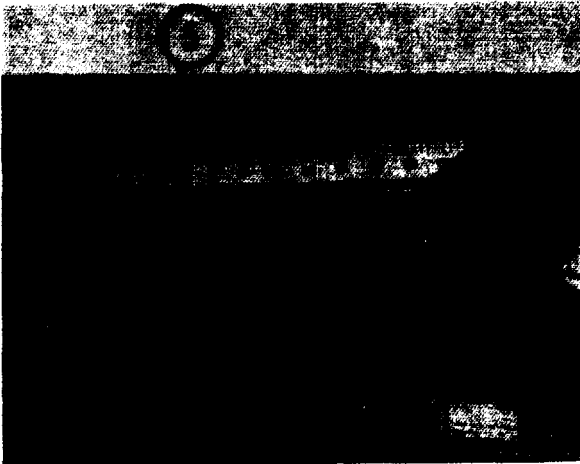
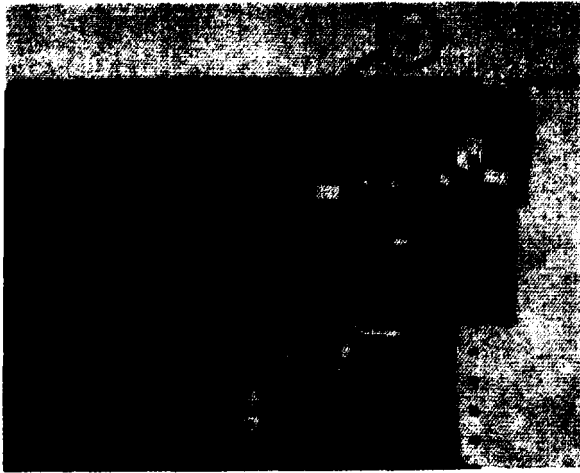

Install

1. Power OFF printer (para 2-7).
2. Open operator door.
3. Lift up hammer bank latch handle to open hammer bank.
4. Open band cover.
5. Loosen knob.
6. Slide tensioner spool in direction shown.
7. Hold tape so top of form hole in channel 1 appears on upper half of tape.

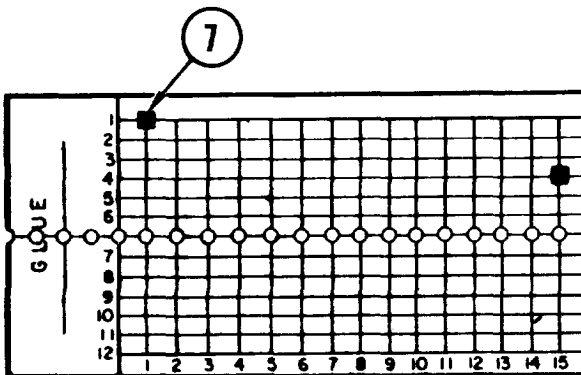

2-14. INSTALL/REMOVE VFU TAPE (CONT)

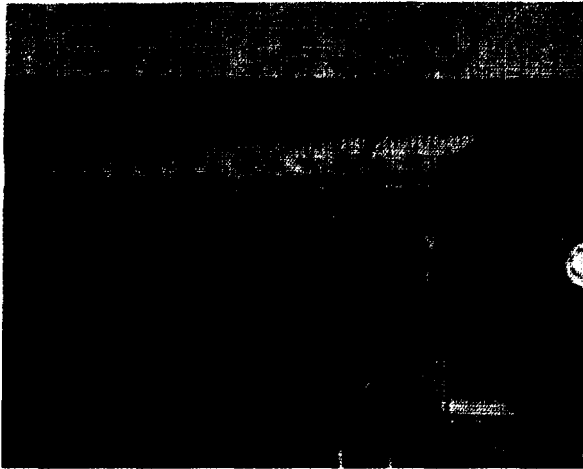

8. Insert tape into tape reader head.
9. Guide tape around outside of both sprockets.

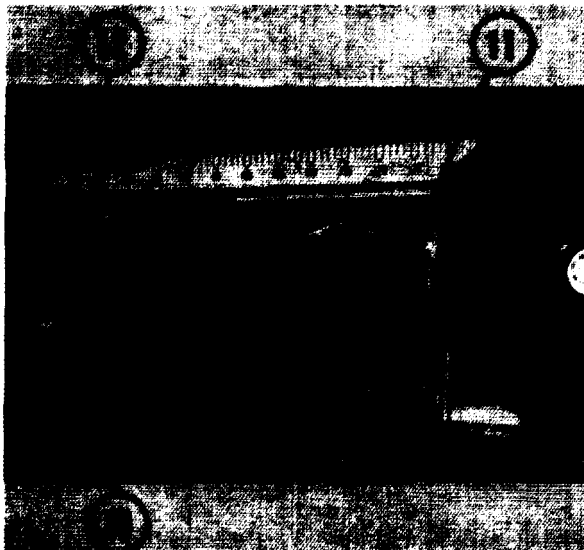

10. Slide tensioner spool in direction shown.
11. Make sure sprocket holes fit tightly over sprocket pins.

CAUTION

Tensioner knob breaks easily. Do not overtighten.

12. Snug knob down on tensioner spool.

13. Power ON printer (para 2-7).

14. Press TOP OF FORM switch.

15. Reset top of form setting (para 2-8, Install, steps 21-26).

16. Close band cover.

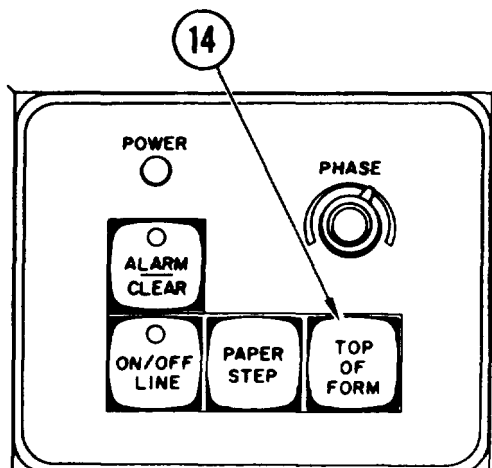

2-14. INSTALL/REMOVE VFU TAPE (CONT)

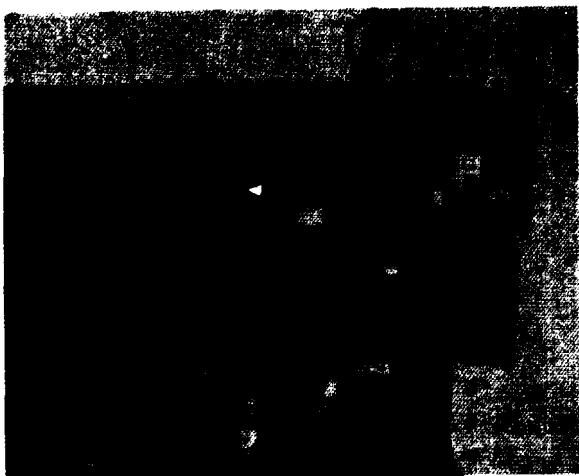

17. Lower hammer bank latch handle to press into locked position.
18. Close operator door.

Remove

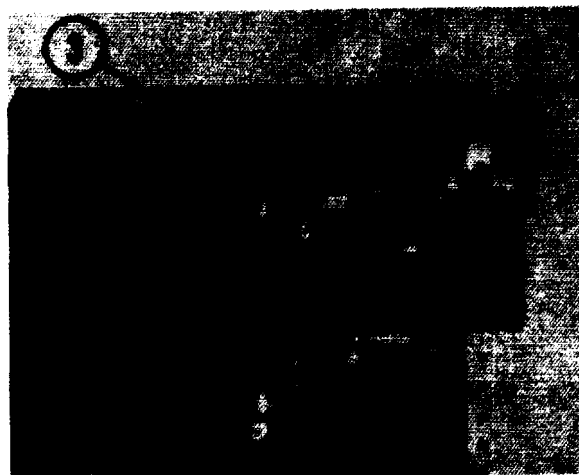

1. Power OFF printer (para 2-7).
2. Open operator door.
3. Lift up hammer bank latch handle to open hammer bank.
4. Open band cover.



5. Loosen knob.
6. Slide tensioner spool in direction shown.

2-14. INSTALL/REMOVE VFU TAPE (CONT)

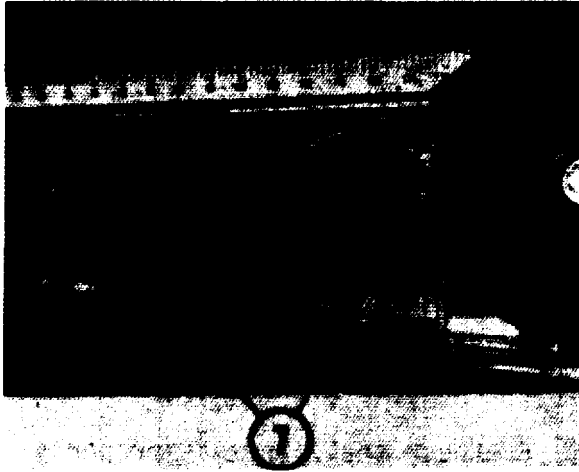

7. Slip tape over drive sprocket and tensioner spool. Lift tape off VFU assembly.
8. Close band cover.
9. Lower hammer bank latch handle, and press into locked position.
10. Close operator door.

2-15. SELF-TEST/OPERATE LINE PRINTER

1. Power OFF printer (para 2-7).
2. Check that VFU tape is properly installed (para 2-14).
3. Check that character band is properly installed (para 2-10).
4. Check that ribbon cartridge is properly installed (para 2-9, Replace, steps 2-14).
5. Power ON printer (para 2-7).
6. Check that paper is properly installed (para 2-8).
7. Open operator door.
8. Set 6/8 LINES switch to desired lines per inch.
9. Set TEST switch to full right position.
10. Close operator door.

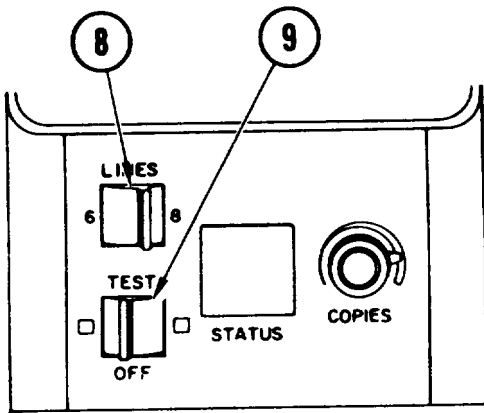

11. Press ON/OFF LINE switch to start self test.

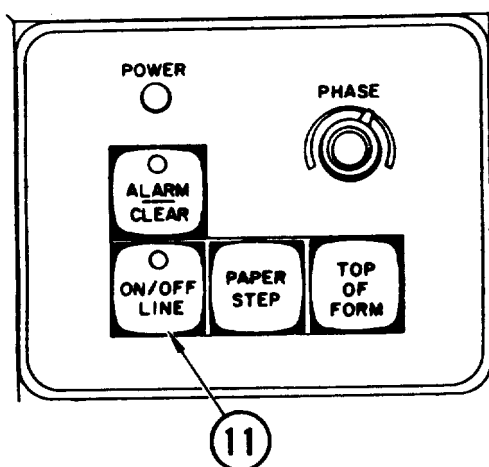

2-15. SELF-TEST/OPERATE LINE PRINTER (CONT)

```

*:(,)'9%+_8ZY7XW6VU5:
:(,)'9%+_8ZY7XW6VU5Sf
(,)'9%+_3ZY7XW6VU5SRl
,)'9%+_8ZY7XW6VU5SRQ-
)'9%+_8ZY7XW6VU5SRQ4l
'9%+_8ZY7XW6VU5SRQ4P
9%+_8ZY7XW6VU5SRQ4PQ
%+_8ZY7XW6VU5SRQ4PD3l
+_8ZY7XW6VU5SRQ4PD3Nl
_8ZY7XW6VU5SRQ4PD3NM:
8ZY7XW6VU5SRQ4PD3NM2l
    
```

12. Allow 10 or 12 lines of the sliding pattern to be printed, then press ON/OFF LINE switch to stop print.
13. Open operator door and check printout. If characters or lines are missing, tell your supervisor maintenance is required.

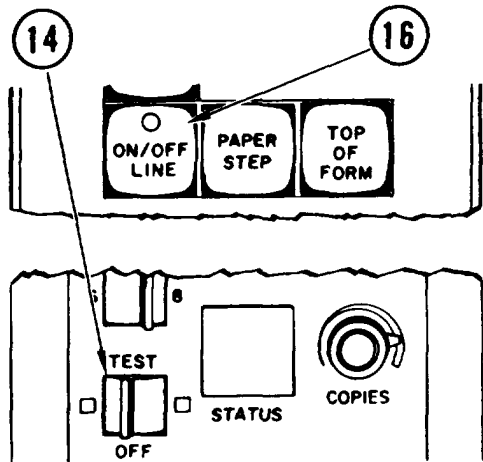

14. Set TEST switch to full left position.
15. Close operator door.
16. Press ON/OFF LINE switch to start print.

```

      (17) (19)
HHHHHHHHHHHHHHHHHHHHHHHH
HHHHHHHHHHHHHHHHHHHHHHHH
HHHHHHHHHHHHHHHHHHHHHHHH
HHHHHHHHHHHHHHHHHHHHHHHH
HHHHHHHHHHHHHHHHHHHHHHHH
HHHHHHHHHHHHHHHHHHHHHHHH
HHHHHHHHHHHHHHHHHHHHHHHH
HHHHHHHHHHHHHHHHHHHHHHHH
HHHHHHHHHHHHHHHHHHHHHHHH
HHHHHHHHHHHHHHHHHHHHHHHH
HHHHHHHHHHHHHHHHHHHHHHHH
HHHHHHHHHHHHHHHHHHHHHHHH
HHHHHHHHHHHHHHHHHHHHHHHH
    
```

17. Allow 10 or 12 lines of the fixed pattern to be printed. Then press ON/OFF LINE switch to stop-print.
18. Open operator door.
19. Check if character printout appears as shown.
 - If adjustments are needed, do steps 20-21
 - If not, go to step 22

2-15. SELF-TEST/OPERATE LINE PRINTER (CONT)

NOTE

Optimum PHASE control setting for single part paper is at or near center position. If good quality print can only be achieved by setting the PHASE control to its fully clockwise or counterclockwise position, tell your supervisor maintenance is required.

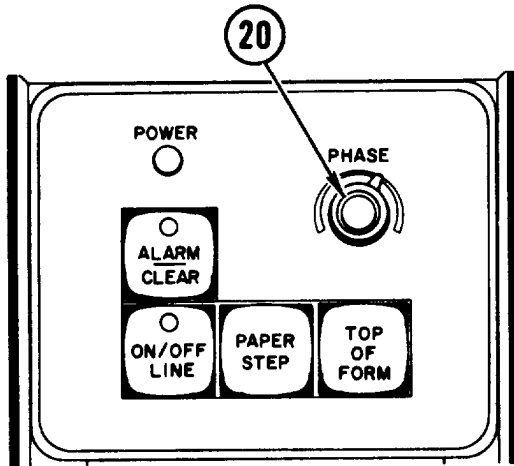

20. Adjust PHASE control knob to print density.
 - If character is light on left side, turn knob counterclockwise
 - If character is light on right side, turn knob clockwise
21. Repeat steps 15 thru 21 until desired print quality is obtained. If proper print quality cannot be obtained, tell your supervisor maintenance is required.

NOTE

COPIES control knob should be set at minimum setting needed to obtain clear copy on the back copy. This will extend the life of the print hammers.

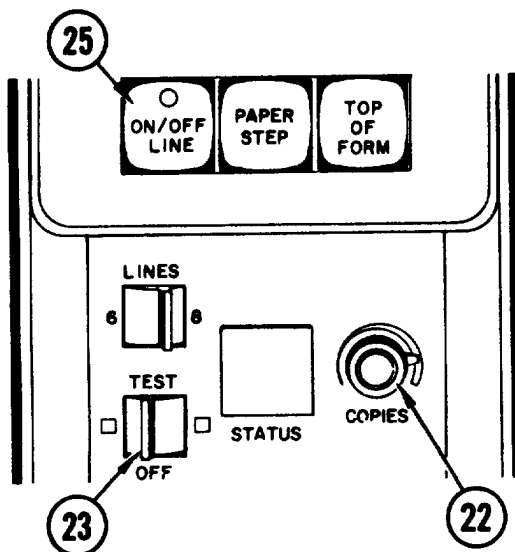

22. Set COPIES control knob in center position.
23. Set TEST switch to far right position.
24. Close operator door.
25. Press ON/OFF LINE switch to start print.
26. Allow 10 or 12 lines of the sliding pattern to be printed, then press ON/OFF LINE switch to stop print.
27. Press TOP OF FORM switch two or three times.

2-15. SELF-TEST/OPERATE LINE PRINTER (CONT)

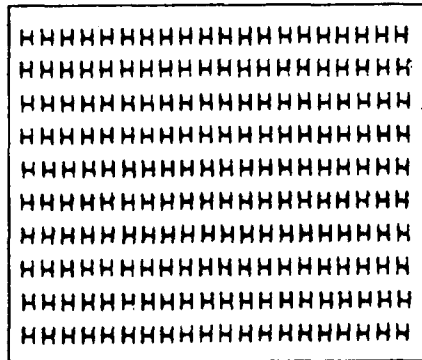

NOTE

In some installations printer must be pulled away from wall before acoustic cabinet rear doors can be opened. See your system manual for access instructions.

28. Open acoustic cabinet rear doors.
29. Check print density on back copy of paper.
 - If print is too light, open operator door and turn COPIES control knob clockwise
 - If print is too dark, open operator door and turn COPIES control knob counterclockwise
 - If print density is satisfactory open operator door, and go to step 31

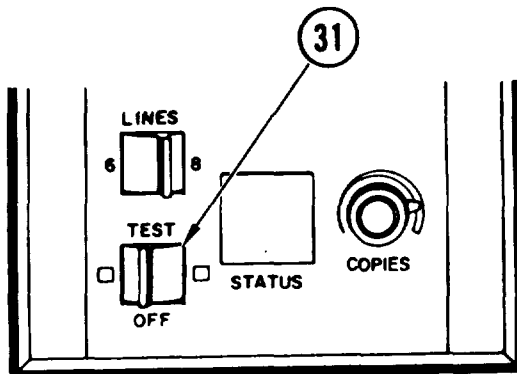

30. Repeat steps 24-29 as required to obtain desired print density, then go to step 31.
31. Set TEST switch to center (OFF) position.
32. Close operator door.

NOTE

In some installations printer, must be pushed back against wall after acoustic cabinet rear doors are closed. See your system manual.

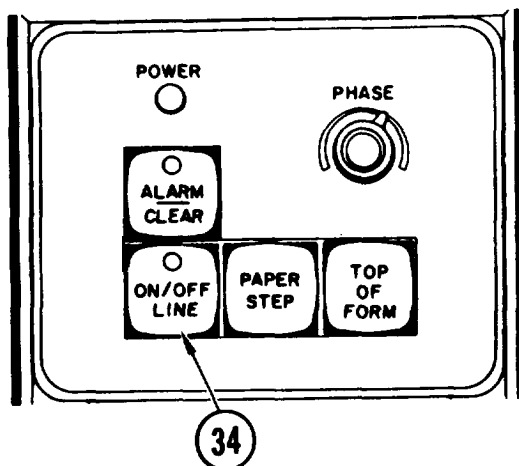

33. Close acoustic cabinet rear doors.
34. Press ON/OFF LINE switch to set printer on line. Make sure ON/OFF LINE indicator is lit.
35. When printing operation is completed, power OFF printer (para 2-7).

2-16. PREPARATION FOR MOVEMENT

Your system manual contains instructions for preparing the line printer for movement. In most installations, unused paper, and sometimes the ribbon cartridge are removed and stored to prepare the line printer for movement.

2-17. OPERATING INSTRUCTIONS ON DECALS AND INSTRUCTION PLATES

Five decals and one instruction plate contain information or instructions relating to operation of the printer (fig. 2-4).

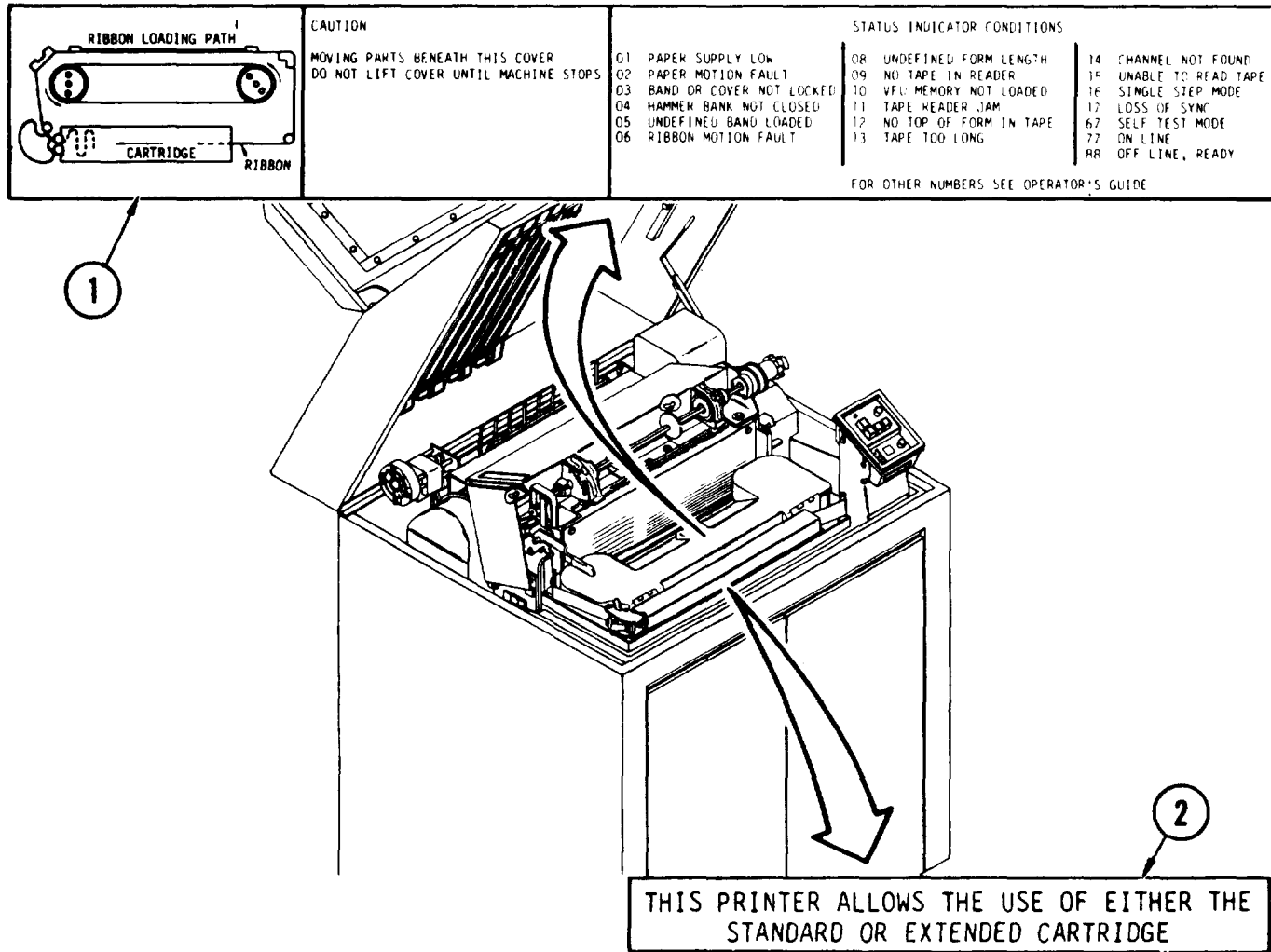

- ① Top Ribbon Band Cover Decal - Contains ribbon loading instructions and troubleshooting information (table 3-1).
- ② Front Ribbon Cover Decal - Contains instructions on use of alternate ribbon cartridges.

Figure 2-4. Operator Decals (1 of 3)

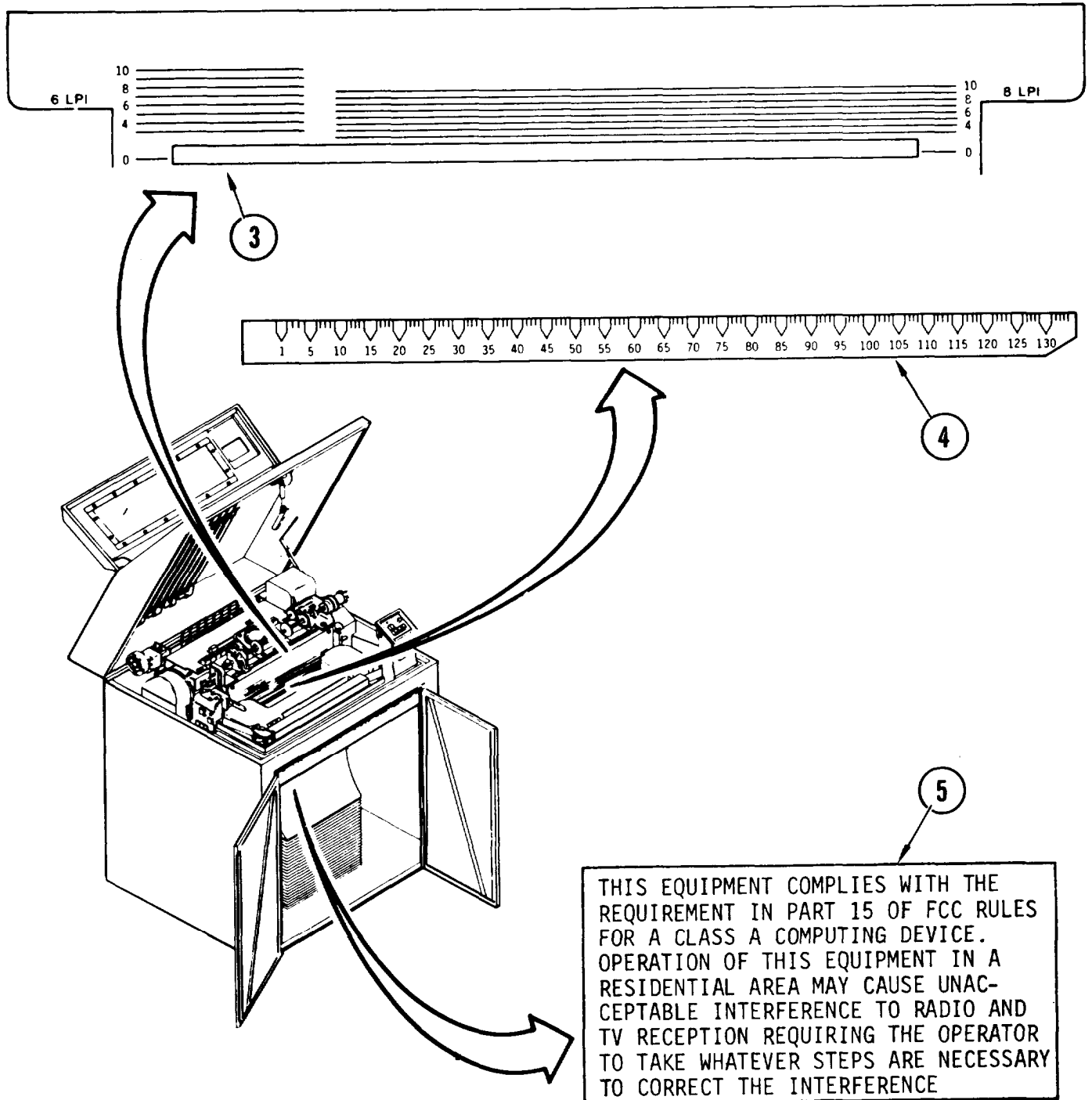

- ③ Hammer Bank Instruction Plate - Contains Top of Form Index Markings used in setting top of form on paper form.
- ④ Forms Alinement Decal - Used to aline first print column on paper form.
- ⑤ Class A Computing Device Decal - Informs operator about consequences of operating line printer in certain areas.

Figure 2-4. Operator Decals (2 of 3)

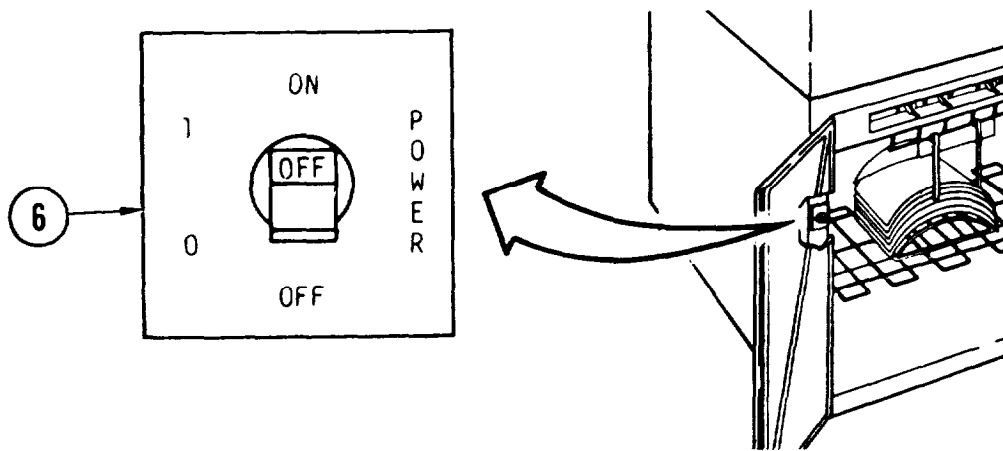

⑥ POWER ON/OFF Decal - Provides information for powering ON/OFF the line printer.

Figure 2-4. Operator Decals (3 of 3)

Section IV. OPERATION UNDER UNUSUAL CONDITIONS

2-18. OPERATION IN UNUSUAL WEATHER

The line printer is designed to operate normally in a climate controlled area protected from dust and extreme dryness. If the climate control equipment fails, you may continue to operate the line printer if the room temperature is not lower than 50°F (10°C) or higher than 100°F (38°C).

WARNING

Do not allow wet cloths used for emergency humidification to drip on floor or near electronic equipment in operating area. A shock hazard will be present.

When operating in extremely dry climate you must use a humidifier to raise the relative humidity above 20%. If the humidifier fails, soak cloths or towels with water and hang them in the work area away from equipment. The evaporation which results will raise the humidity and allow you to continue operation. Monitor the humidity while you operate to make sure it is at least 20%.

2-19. EMERGENCY PROCEDURES

If the ac power goes out at the power source while the line printer is on, power OFF the printer at the ON/OFF POWER switch. When ac power is restored, restart the printer. If the printer was operating on line before power interruption, you will have to start the program being run from the beginning.

If ac power interruption affects entire ADP system, see your system manual for start-up procedure.

CHAPTER 3 MAINTENANCE INSTRUCTIONS

Index of Maintenance Procedures

Paragraph No.	Title	Page No.
3-4	Check/Adjust Ribbon Cartridge	3-11
3-5	Check/Adjust Character Band	3-14
3-6	Clean Character Band	3-16
3-7	Clean Line Printer	3-18
3-8	Clean Paper Motion Sensor	3-21

Section I. LUBRICATION INSTRUCTIONS

3-1. LUBRICATION

The line printer requires no lubrication by the operator.

Section II. TROUBLESHOOTING PROCEDURES

3-2. GENERAL

Table 3-1 lists the common malfunctions which you may find during the operation or maintenance of the line printer or its components. You should perform the tests/inspections and corrective actions in the order listed.

All STATUS indicator alphanumeric codes used for this model of the line printer are contained in table 3-1. A flashing display of any code means possible lost data on last line printed (table 3-1, item 51).

Random codes, other than those listed in table 3-1, can appear on the STATUS indicator. If this persists after corrective action (table 3-1, item 50), it indicates a malfunction which must be checked by maintenance personnel.

This manual cannot list all malfunctions that may occur, nor all tests or inspections and corrective actions. If a malfunction is not listed or is not corrected by listed corrective actions, notify your supervisor.

Table 3-1. Troubleshooting

MALFUNCTION	TEST OR INSPECTION	CORRECTIVE ACTION
1. PRINTER WILL NOT POWER ON.	<p>Step 1. Check if ac power cord is plugged into outlet.</p> <p style="padding-left: 40px;">If not, plug it in.</p> <p>Step 2. Check if power switch is ON.</p> <p style="padding-left: 40px;">If not, set it ON.</p> <p>Step 3. If printer is plugged in and powered ON, but will not run,</p> <p style="padding-left: 40px;">Tell your supervisor.</p>	
2. STATUS CODE BLANK (FAULT UNDEFINED).	<p>Power OFF, then power ON printer (para 2-7).</p> <p style="padding-left: 40px;">If fault persists, tell your supervisor maintenance is required.</p>	
3. STATUS CODE 00 (PROCESSOR BOARD PROM NOT PROPERLY CONNECTED).	<p>Power OFF, then power ON printer (para 2-7).</p> <p style="padding-left: 40px;">If fault persists, tell your supervisor maintenance is required.</p>	
4. STATUS CODE 01 (PAPER SUPPLY LOW).	<p>Check paper supply.</p> <p style="padding-left: 40px;">Install paper (para 2-8), press ALARM/CLEAR switch. If fault persists, tell your supervisor maintenance is required.</p>	
5. STATUS CODE 02 (PAPER MOTION FAULT).	<p>Step 1. Check paper motion path (para 2-8).</p> <p style="padding-left: 40px;">Clear paper jam, and press ALARM/CLEAR switch.</p> <p>Step 2. Check sprocket width.</p> <p style="padding-left: 40px;">Adjust sprocket width (para 2-8), and press ALARM/CLEAR switch.</p>	

Table 3-1. Troubleshooting -- Continued

MALFUNCTION	TEST OR INSPECTION	CORRECTIVE ACTION
	Step 3.	Check alinement of paper pin-feed holes on sprocket pins. Aline pin-feed holes on sprocket pins, and press ALARM/CLEAR switch.
	Step 4.	Check if paper release lever is down in locked position. Push paper release lever down into locked position, and press ALARM/CLEAR switch. If fault persists, tell your supervisor maintenance is required.
6.	STATUS CODE 03 (CHARACTER BAND NOT TIGHT, OR BAND COVER NOT CLOSED).	
	Step 1.	Check character band tension. Adjust character band tension (para 3-5).
	Step 2.	Check band cover. Close band cover. If fault persists, tell your supervisor maintenance is required.
7.	STATUS CODE 04 (HAMMER BANK NOT CLOSED).	
	Check hammer bank position. Press down hammer bank latch handle into locked position. If fault persists, tell your supervisor maintenance is required.	
8.	STATUS CODE 05 (UNDEFINED CHARACTER BAND).	
	Check character band for sets of 96 characters. Install proper character band (para 2-10), and press ALARM/CLEAR switch. If fault persists, tell your supervisor maintenance is required.	
9.	STATUS CODE 06 (RIBBON MOTION FAULT).	
	Step 1.	Check ribbon motion path (para 3-4). Clear ribbon jam, and press ALARM/CLEAR switch.
	Step 2.	Check ribbon cartridge (para 3-4). Adjust ribbon cartridge, and press ALARM/CLEAR switch.

Table 3-1. Troubleshooting -- Continued

MALFUNCTION	TEST OR INSPECTION	CORRECTIVE ACTION
	Step 3.	<p>Check ribbon motion sensor (para 3-7).</p> <p>Clean sensor (para 3-7), and press ALARM/CLEAR switch. If fault persists, tell your supervisor maintenance is required.</p>
10.	LEFT OR RIGHT SIDE OF ALL CHARACTERS MISSING.	
	Step 1.	<p>Check PHASE control settings (para 2-12).</p> <p>Adjust PHASE control settings.</p>
	Step 2.	<p>Check COPIES control settings (para 2-12).</p> <p>Adjust COPIES control settings. If fault persists, tell your supervisor maintenance is required.</p>
11.	CHARACTERS SMEARED.	
	Step 1.	<p>Check character band.</p> <p>Clean character band (para 3-6), and press ALARM/CLEAR switch.</p>
	Step 2.	<p>Check if ribbon meets thickness and length specifications (para 1-15).</p> <p>Install new ribbon cartridge (para 2-9), and press ALARM/CLEAR switch.</p>
	Step 3.	<p>Check if paper meets weight and thickness specifications (para 1-15).</p> <p>Install new paper supply (para 2-8). Press ALARM/CLEAR switch. If fault persists, tell your supervisor maintenance is required.</p>
12.	CARBON COPIES TOO LIGHT OR TOO DARK.	
	Step 1.	<p>Check COPIES control adjustment (para 2-12).</p> <p>Adjust COPIES control.</p>
	Step 2.	<p>Check that no more than six-part copy is installed in printer.</p> <p>Install six-part paper or less (para 2-8). press ALARM/CLEAR switch.</p>

Table 3-1. Troubleshooting -- Continued

MALFUNCTION	TEST OR INSPECTION	CORRECTIVE ACTION
	Step 3. Check if paper meets weight specifications (para 1-15).	Install paper that meets specifications (para 2-8). Press ALARM/CLEAR switch.
	Step 4. Check if carbon copy meets weight specifications (para 1-15).	Install paper with carbon copy that meets specifications (para 2-8). Press ALARM/CLEAR switch. If fault persists, tell your supervisor maintenance is required.
13. STATUS CODE 08 (UNDEFINED FORM LENGTH SELECTED).	Check 6/8 LINES switch (para 2-12).	Set 6/8 LINES switch to desired number of lines per inch, and press ALARM/CLEAR switch. If fault persists, tell your supervisor maintenance is required.
14. STATUS CODE 09 (NO TAPE IN TAPE READER).	Check if VFU tape is installed.	Install VFU tape (para 2-11), and press ALARM/CLEAR switch.
15. STATUS CODE 10 (VFU MEMORY NOT LOADED).	Press ALARM/CLEAR switch.	Press VFU tape read request switch (para 2-11). Press ALARM/CLEAR switch.
16. STATUS CODE 11 (VFU TAPE READER JAM).	Check VFU tape (para 2-11).	Replace or re-install VFU tape (para 2-11). Press ALARM/CLEAR switch. If fault persists, tell your supervisor maintenance is required.
17. STATUS CODE 12 (NO TOP OF FORM IN VFU TAPE).	Check if VFU tape contains top of form hole (fig. 1-9).	If necessary, prepare new VFU tape (para 3-9), and press ALARM/CLEAR switch. If fault persists, tell your supervisor maintenance is required.

Table 3-1. Troubleshooting -- Continued

MALFUNCTION	TEST OR INSPECTION	CORRECTIVE ACTION
18. STATUS CODE 13 (VFU TAPE TOO LONG).	Check if tape is longer than 144 lines.	Install tape that is no longer than 144 lines (para 2-11). Press ALARM/CLEAR switch.
19. STATUS CODE 14 (VFU TAPE CHANNEL NOT FOUND).	Check if VFU tape is installed correctly (para 2-11).	Re-install VFU tape (para 2-11), and press ALARM/CLEAR switch. If fault persists, tell your supervisor maintenance is required.
20. STATUS CODE 15 (PRINTER UNABLE TO READ TAPE).	Check VFU tape for tears and excess wear.	Replace VFU tape (para 2-11), and press ALARM/CLEAR switch. If fault persists, tell your supervisor maintenance is required.
21. STATUS CODE 16 (SINGLE STEP MODE BOF OPTION IS SET AND PAPER IS LOW).	Press ALARM/CLEAR switch, and wait until paper steps to bottom of form. Then press ON/OFF/LINE switch.	Install paper (para 2-8).
22. STATUS CODE 17 (LOSS OF PRINT SYNC).	Check last line of print for incorrect data.	Press ALARM/CLEAR switch. If fault persists, tell your supervisor maintenance is required.
23. STATUS CODE 20 (NO DATA COMPARISON).	Press ALARM/CLEAR switch.	If fault persists, tell your supervisor maintenance is required.
24. STATUS CODE 21 (PRINT INHIBIT).	Power OFF, then power ON printer (para 2-7).	If fault persists, tell your supervisor maintenance is required.

Table 3-1. Troubleshooting -- Continued

MALFUNCTION	TEST OR INSPECTION	CORRECTIVE ACTION
25. STATUS CODE 22 (INTERLOCK CABLE ERROR).	Power OFF, then power ON printer (para 2-7).	If fault persists, tell your supervisor maintenance is required.
26. STATUS CODE 23 (I/O PARITY ERROR, DATA LOAD).	Press ALARM/CLEAR switch.	If fault persists, tell your supervisor maintenance is required.
27. STATUS CODE 24 (TOO MANY CONSECUTIVE CARRIAGE RETURNS).	Press ALARM/CLEAR switch.	If fault persists, tell your supervisor maintenance is required.
28. STATUS CODE 25 (FORMAT CODE NOT RECOGNIZED).	Press ALARM/CLEAR switch.	If fault persists, tell your supervisor maintenance is required.
29. STATUS CODE 26 (DAVFU STOP CODE ERROR).	Press ALARM/CLEAR switch.	If fault persists, tell your supervisor.
30. STATUS CODE 27 (DAVFU DATA TRANSFER EXCEEDS 286 CHARACTERS).	Press ALARM/CLEAR switch.	If fault persists, tell your supervisor.
31. STATUS CODE 28 (VFU CHECK SUM ERROR).	Press ALARM/CLEAR switch.	If fault persists, tell your supervisor maintenance is required.
32. STATUS CODE 29 (I/O PARITY ERROR DAVFU LOAD),	Press ALARM/CLEAR switch.	If fault persists, tell your supervisor maintenance is required.

Table 3-1. Troubleshooting -- Continued

MALFUNCTION	TEST OR INSPECTION	CORRECTIVE ACTION
33. STATUS CODE 30 (BAD VFU MEMORY).	Power OFF, then power ON printer (para 2-7).	If fault persists, tell your supervisor maintenance is required.
34. STATUS CODE 40 (BAND SPEED FAULT).	Step 1. Check cleanliness of character band area.	If necessary, clean character band area (para 3-7).
	Step 2. Check that no more than six-part paper is installed in printer.	Install no more than six-part paper (para 2-8). If fault persists, tell your supervisor maintenance is required.
35. STATUS COXDE 41 (PAPER DRIVE/CLAMP SYSTEM FAULT).	Power OFF, then power ON printer (para 2-7).	If fault persists, tell your supervisor maintenance is required.
36. STATUS CODE 42 (ODD HAMMER SYSTEM FAULT).	Power OFF, then power ON printer (para 2-7).	If fault persists, tell your supervisor maintenance is required.
37. STATUS CODE 43 (EVEN HAMMER SYSTEM FAULT).	Power OFF, then power ON printer (para 2-7).	If fault persists, tell your supervisor maintenance is required.
38. STATUS CODE 44 (+12 VOLT FAULT).	Power OFF, then power ON printer (para 2-7).	If fault persists, tell your supervisor maintenance is required.
39. STATUS CODE 45 (-9 VOLT FAULT).	Power OFF, then power ON printer (para 2-7).	If fault persists, tell your supervisor maintenance is required.
40. STATUS CODE 46 (VCL FAULT).	Power OFF, then power ON printer (para 2-7).	If fault persists, tell your supervisor maintenance is required.
41. STATUS CODE 47 (+38 VOLT FAULT).	Power OFF, then power ON printer (para 2-7).	If fault persists, tell your supervisor maintenance is required.
42. STATUS CODE 48 (TRANSDUCER FAULT).	Power OFF, then power ON printer.	If fault persists, tell your supervisor maintenance is required.

Table 3-1. Troubleshooting -- Continued

MALFUNCTION	TEST OR INSPECTION	CORRECTIVE ACTION
43. STATUS CODE 49 (BAND CURRENT FAULT).	Power OFF, then power ON printer (2-7).	If fault persists, clean character band (para 3-6) and character band area (para 3-7). If fault persists, tell your supervisor maintenance is required.
44. STATUS CODE 50 (SYSTEM STATUS FAULT).	Power OFF, then power ON printer (para 2-7).	If fault persists, tell your supervisor maintenance is required.
45. STATUS CODE 66 (SELF TEST MODE - PRINT INHIBIT SWITCH ON).	Power OFF, then power ON printer.	If fault persists, tell your supervisor maintenance is required.
46. STATUS CODE 67 (SELF TEST MODE).	Place TEST switch in center (OFF) position.	If fault persists, tell your supervisor maintenance is required.
47. STATUS CODE 68 (DAVFU LOAD).	NOTE	Status Code 68 indicates the line printer is operating normally. Take no action.
48. STATUS CODE 76 (ON LINE-PRINT INHIBIT).	Power OFF, then power ON printer (para 2-7).	If fault persists, notify your supervisor maintenance is required.
49. STATUS CODE 77 (ON LINE).	Normal indication.	Continue operation.

Table 3-1. Troubleshooting -- Continued

MALFUNCTION	TEST OR INSPECTION	CORRECTIVE ACTION
50. STATUS CODE 88 (OFF LINE, READY).	Normal indication.	Continue operation.
51. STATUS CODE P (POWER FAULT) .	Power OFF, then power ON printer (para 2-7). If fault persists, tell your supervisor maintenance is required.	
52. STATUS CODE H (HOT CONDITION).	Power OFF, then power ON printer (para 2-7). If fault persists, tell your supervisor maintenance is required.	
53. STATUS CODE C (CLOCK FAULT).	Power OFF, then power ON printer (para 2-7). If fault persists, tell your supervisor maintenance is required.	
54. RANDOM STATUS CODE DISPLAYED.	Power ON/power OFF printer (para 2-7). If fault persists, tell your supervisor maintenance is required.	
55. STATUS CODE FLASHES.	Code indicates possible memory loss on last line printed. Check last form printout against source data. If necessary, restart program. (See your system manual).	

Section III. MAINTENANCE PROCEDURES

3-3. GENERAL

This section contains the maintenance procedures you are authorized to perform on the line printer. These include checks and adjustments, removal and installation of components, cleaning and testing. Operator maintenance on the line printer is required whenever a preventive maintenance check or troubleshooting procedure calls for it.

3-4. CHECK/ADJUST RIBBON AND RIBBON CARTRIDGE

1. Power OFF printer (para 2-7).
2. Open operator door.
3. Lift up hammer bank latch handle to open hammer bank.

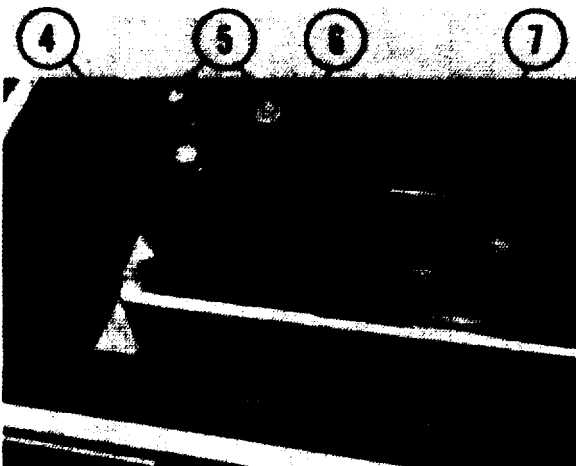
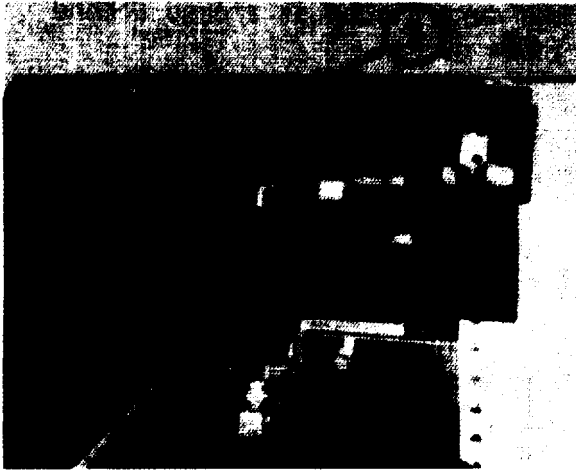

4. Open pivot arm assembly.
5. Make sure ribbon is threaded between pivot arm roller and ribbon drive roller.
6. Make sure ribbon is under light tension.
7. Push ribbon cartridge to the left to make sure it is properly seated. Cartridge should now be locked in position.

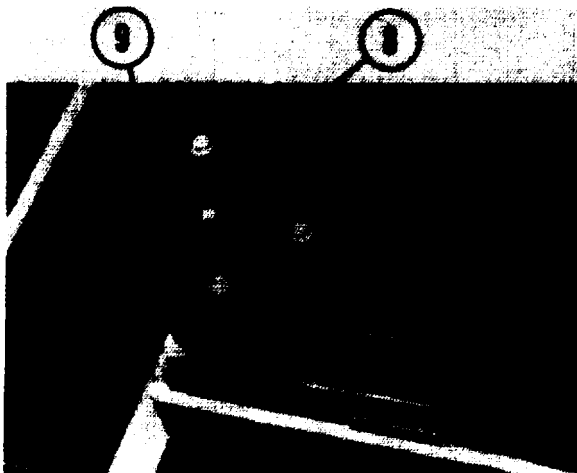

8. Make sure ribbon is around first ribbon guide.
9. Close pivot arm assembly.

3-4. CHECK/ADJUST RIBBON AND RIBBON CARTRIDGE (CONT)

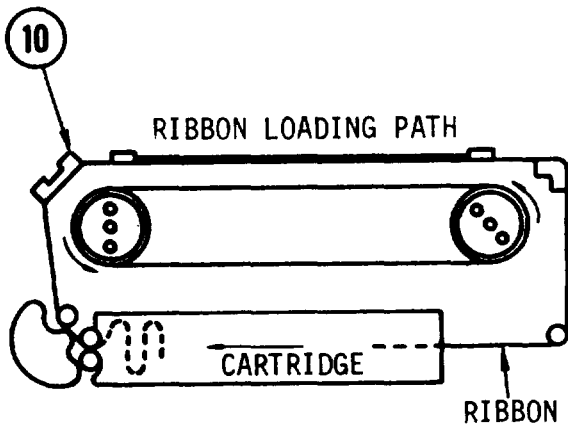

- 10. Make sure ribbon is around second ribbon guide.

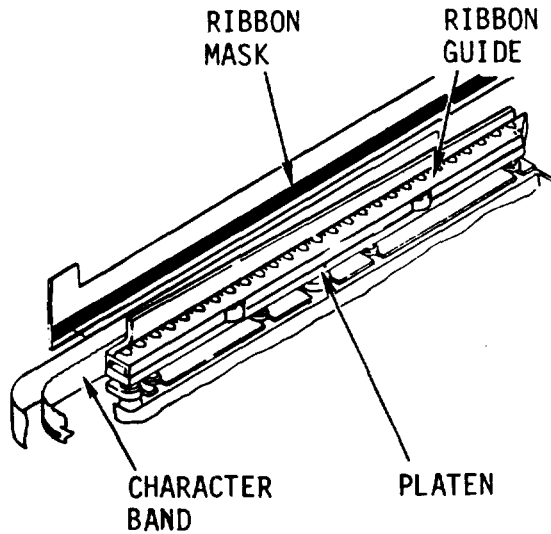

- 11. Make sure ribbon is between ribbon mask and character band as shown.

NOTE

Ribbon moves in a diagonal direction down from second to third ribbon guide.

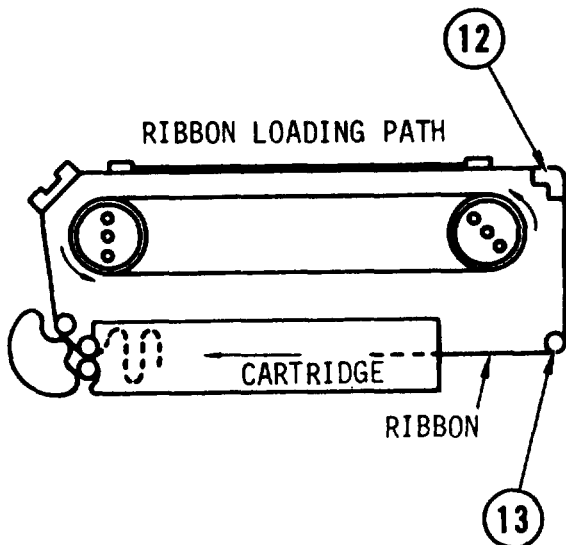

- 12. Make sure ribbon is around base and under upper lip of third ribbon guide.

NOTE

Third ribbon guide is installed on a diagonal, so ribbon tends to slide down guide when tightened.

- 13. Make sure ribbon is around fourth ribbon guide.

3-4. CHECK/ADJUST RIBBON AND RIBBON CARTRIDGE (CONT)

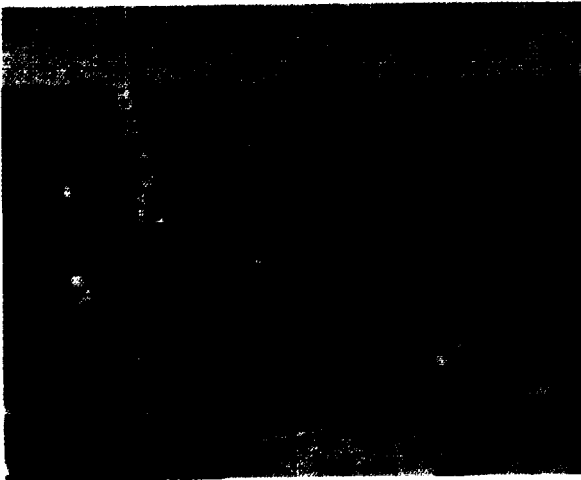

14. Open band cover and rotate either pulley in direction shown to take up ribbon slack.
15. Close band cover.

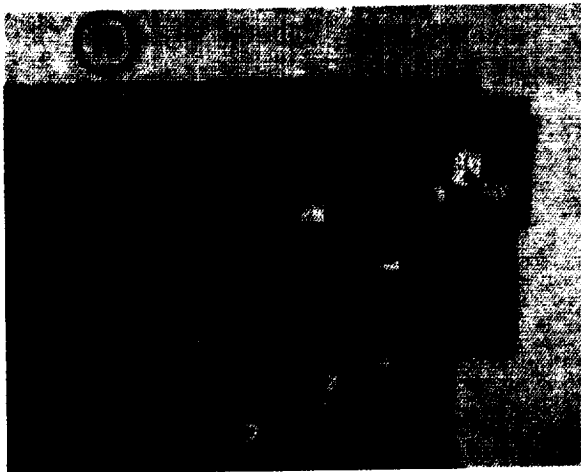

16. Press down on hammer bank latch handle until it locks in place.
17. Close operator door.
18. Power ON printer (para 2-7).

3-5. CHECK/ADJUST CHARACTER BAND

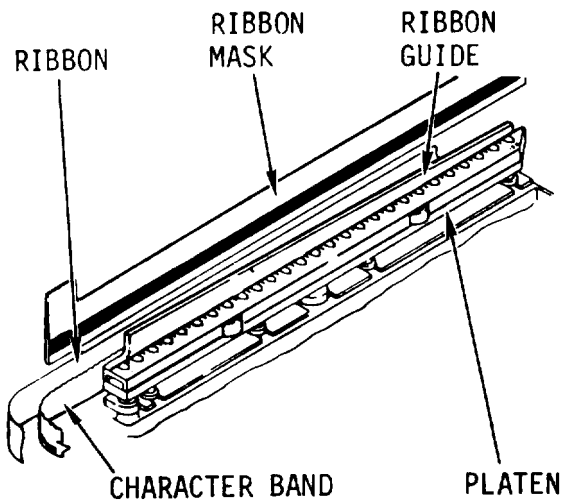
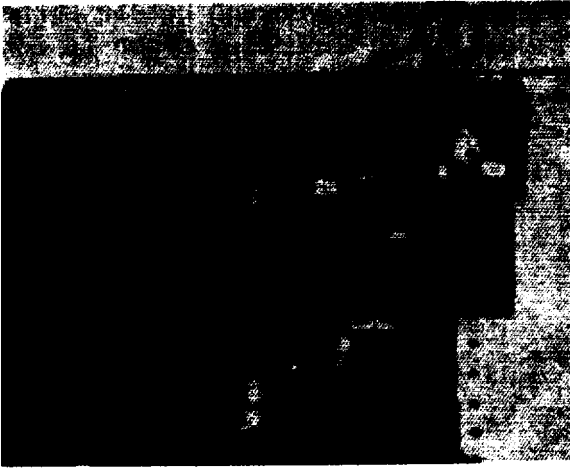

1. Power OFF printer (para 2-7).
2. Pull ac plug from outlet.
3. Open operator door.
4. Lift up hammer bank latch handle to open hammer bank.
5. Open band cover.
6. Make sure character band is installed with scalloped edges on top.

CAUTION

Band must be placed between ribbon and platen. Otherwise, mask can be damaged.

7. Make sure band is installed between ribbon and platen (or ribbon mask and platen if ribbon is not installed).
8. Make sure band release handle has been moved fully to front of printer in direction shown.

3-5. CHECK/ADJUST CHARACTER BAND (CONT)



9. While spinning either pulley in direction shown, observe movement of character band over both edge guide bearings.
 - If character band touches, and rides smoothly and evenly over both edge guide bearings, go to step 10
 - If character band does not touch one or both edges guide bearings, remove band and repeat steps 1 thru 9. If problem remains, notify your supervisor that maintenance is required
 - If character band rides unevenly or roughly over one or both edge guide bearings, remove band and repeat steps 1 thru 9. If problem remains, notify supervisor that maintenance is required

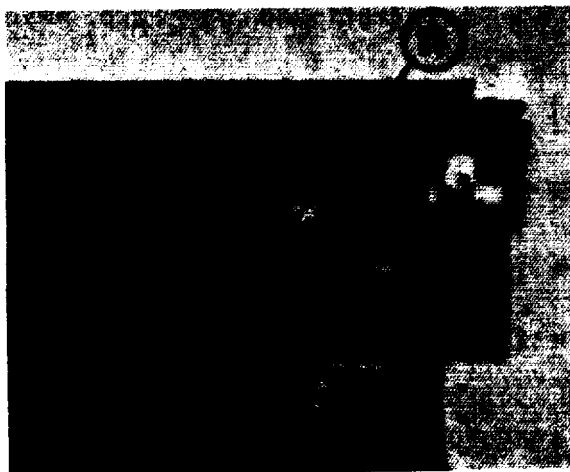

10. Close band cover.
11. Press down on hammer bank latch handle until it locks in place.
12. Close operator door.
13. Plug ac power plug into outlet.
14. Power ON printer (para 2-7).

3-6. CLEAN CHARACTER BAND

INITIAL SETUP

Common Tools

- Stiff bristle brush

Materials/Spare Parts

- Isopropyl alcohol

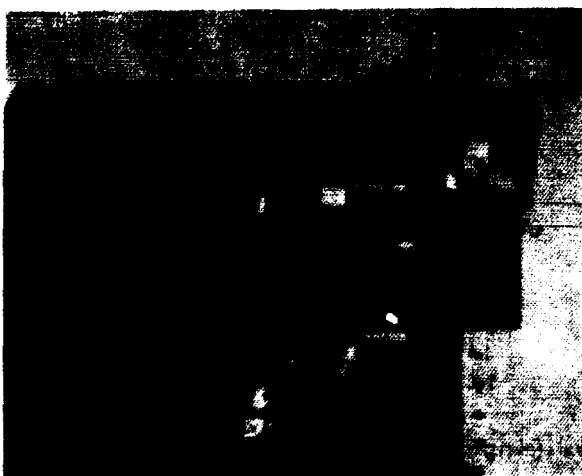

1. Power OFF printer (para 2-7).
2. Pull ac power plug from outlet.
3. Open operator door.
4. Lift up hammer bank latch handle to open hammer bank.
5. Remove ribbon cartridge (para 2-9, Remove, steps 4-6).
6. Remove character band (para 2-10, Remove, steps 6-10).

WARNING

Top edges of band are sharp. Avoid contact.

7. Place character band in a shallow pan.

WARNING

Isopropyl alcohol is flammable. Keep away from high heat or open flame.

8. Place isopropyl alcohol in bottle equipped with spray nozzle.
9. Saturate band.
10. Using a small stiff bristle brush, clean type faces thoroughly.
11. Clean both sides of entire band.
12. Allow band to drip dry.

3-6. CLEAN CHARACTER BAND (CONT)

13. Replace character band and ribbon cartridge (para 2-10 Replace, steps 1-11).
14. Close operator door.
15. Plug ac power plug into outlet.
16. Power ON printer (para 2-7).

3-7. CLEAN LINE PRINTER

INITIAL SETUP

Common Tools

- Vacuum cleaner
- Non-magnetic brush

Materials/Spare Parts

- Isopropyl alcohol
- Clean, lint-free cloth

1. Remove paper (para 2-8, steps 1-9).
2. Power OFF printer (para 2-7).
3. Pull ac power cord from outlet.
4. Remove ribbon cartridge (para 2-9).
5. Remove character band (para 2-10, Remove, steps 6-10).
6. Vacuum paper dust and ribbon lint from all areas accessible through operator door.

WARNING

Isopropyl alcohol is flammable. Do not use near high heat or open flame.

7. Dampen clean lint-free cloth with isopropyl alcohol.
8. Clean character band track on side of band pulleys.

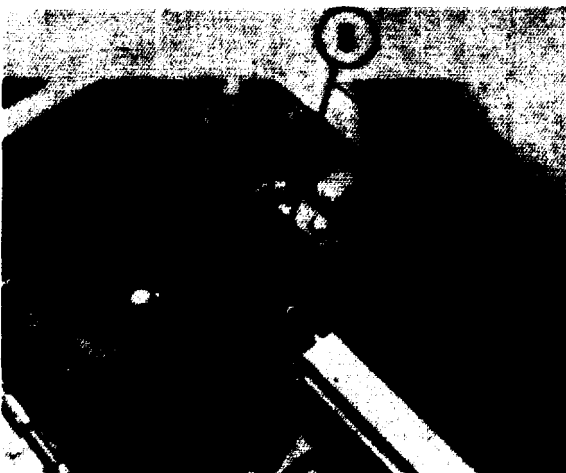

3-7. CLEAN LINE PRINTER (CONT)

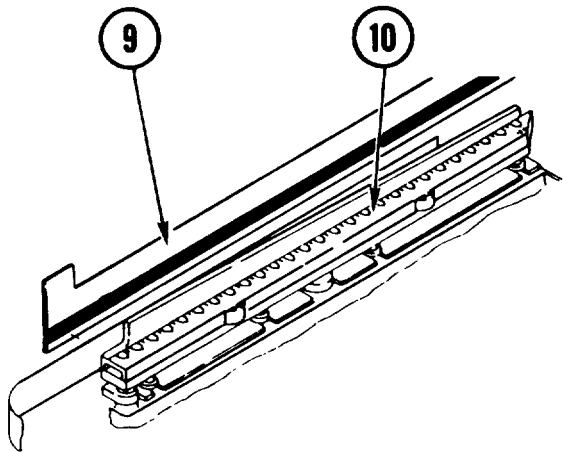

- 9. Wipe inside area of ribbon mask.
- 10. Wipe inside area of platen.

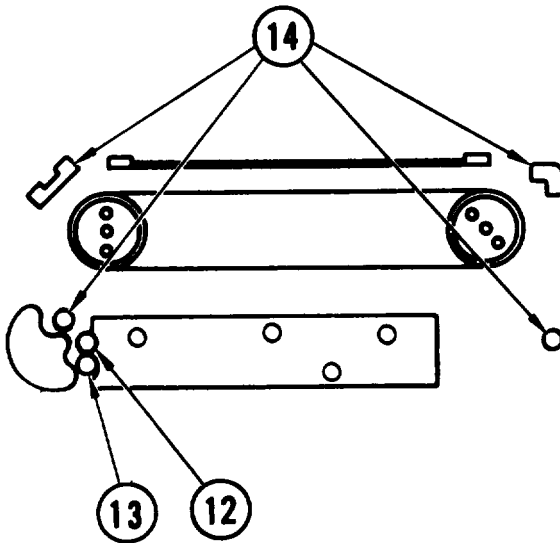

- 11. Close band cover.
- 12. Wipe drive roller clean.
- 13. Wipe idler roller clean.
- 14. Wipe all ribbon guides clean.

NOTE

Grooves in magnetic capstan tend to collect lint and ink buildup.

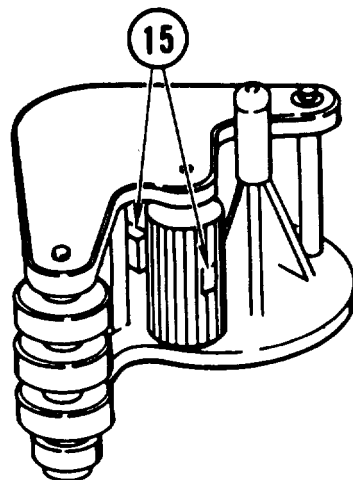

- 15. Clean magnetic capstan and ribbon sensor with cloth or non-magnetic brush, rotating magnetic capstan as necessary to clean all grooves.
- 16. Clean paper motion sensor (para 3-8, steps 3-6).

NOTE

In some installations printer must be pulled away from wall so acoustic cabinet rear doors can be opened. See your system manual for instructions.

3-7. CLEAN LINE PRINTER (CONT)

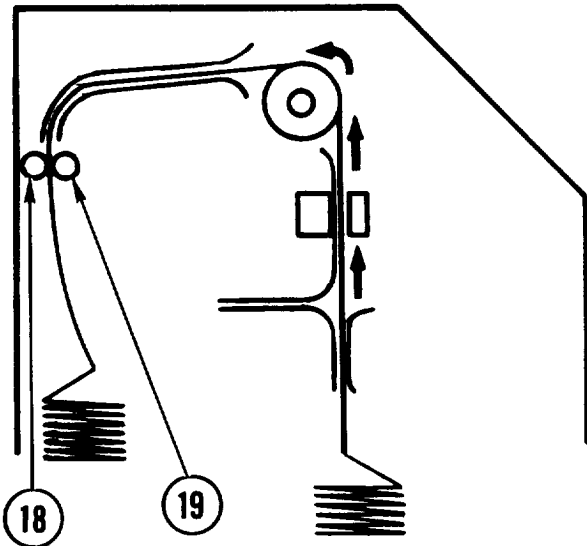

17. Open cabinet rear doors.
18. Lift up and wipe all pressure rollers clean.
19. Wipe all drive rollers clean.

NOTE

In some installations printer must be pushed back against the wall after rear doors are closed. See your system manual for close up instructions.

20. Close acoustic cabinet rear doors and open band cover.
21. Replace character band (para 2-10, Replace, steps 1-9).
22. Replace ribbon cartridge (para 2-9, Replace, steps 2-14).
23. Push ac power cord into outlet.
24. Install paper (para 2-8).

3-8. CLEAN PAPER MOTION SENSOR

INITIAL SETUP

Materials/Spare Parts

- Isopropyl alcohol
- Clean, lint-free cloth

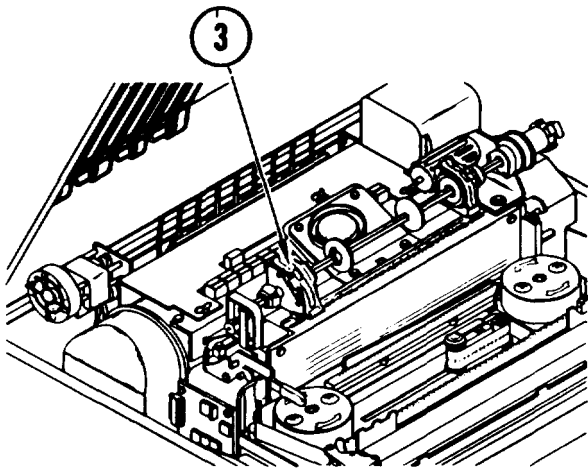

1. Remove paper (para 2-8, Remove, steps 1-8).
2. Power OFF printer (para 2-7).
3. Open cover on left sprocket.

WARNING

Isopropyl alcohol is flammable. Do not use near high heat or open flame.

4. Dampen lint-free cloth with alcohol.

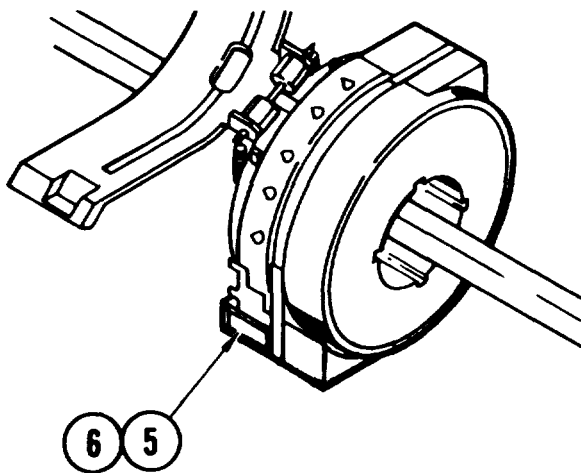

5. Locate paper motion sensor under left sprocket. Wipe clean.
6. Dry sensor with clean, dry, lint-free cloth.
7. Install paper (para 2-8).

APPENDIX A REFERENCES

A-1. SCOPE

This appendix lists all forms, field manuals and technical manuals referenced in, or required for use with, this technical manual.

A-2. FORMS

Equipment Inspection and Maintenance Worksheet DA Form 2404
Quality Deficiency Report Form SF 368
Recommended Changes to Equipment Technical Manuals DA Form 2028-2
Recommended Changes to Publications and Blank Forms DA Form 2028

A-3. TECHNICAL MANUALS

Hand Receipt Manual: Line Printer RP-309/MYQ-4A TM 11-7025-232-10-HR
The Army Maintenance Management System (TAMMS) TM 38-750

A-4. MISCELLANEOUS PUBLICATIONS

Consolidated Index of Army Publications and Blank Forms DA PAM 310-1

APPENDIX B

COMPONENTS OF END ITEM AND BASIC ISSUE ITEMS LISTS

Section I. INTRODUCTION

B-1. SCOPE

This appendix lists components of end item and basic issue items for the line printer to help you inventory items required for safe and efficient operation.

B-2. GENERAL

The Components of End Item and Basic Issue Items Lists are divided into the following sections:

a. Section II. Components of End Item. This listing is for informational purposes only, and is not authority to requisition replacements. These items are part of the end item, but are removed and separately packaged for transportation or shipment. As part of the end item, these items must be with the end item whenever it is issued or transferred between property accounts. Illustrations are furnished to assist you in identifying the items.

b. Section III. Basic Issue Items. These are the minimum essential items required to place the line printer in operation, to operate it, and to perform emergency repairs. Although shipped separately packaged BII must be with the line printer during operation and whenever it is transferred between property accounts. The illustrations will assist you with hard-to-identify items. This manual is your authority to request/requisition replacement BII, based on TOE/MTOE authorization of the end item.

B-3. EXPLANATION OF COLUMNS

The following provides an explanation of columns found in the tabular listings:

Column (1) -- Illustration Number (Illus Number). This column indicates the number of the illustration in which the item is shown.

Column (2) -- National Stock Number. Indicates the National stock number assigned to the item and will be used for requisitioning purposes.

Column (3) -- Description. Indicates the National item name and, if required, a minimum description to identify and locate the item. The last line for each item indicates the Federal Source Code for Manufacturer (FSCM) in parentheses followed by the part number. If item needed differs for different models of this equipment, the model is shown under the "Usable On" heading in this column.

These codes are identified as:

Code	Used On
PAA	Model XXX
PAB	Model XXXX
PAC	Model XXXX

Column (4) -- Unit of Measure (U/M). Indicates the measure used in performing the actual operational/maintenance function. This measure is expressed by a two-character alphabetical abbreviation (e.g., ea, in., pr).

Column (5) -- Quantity required (Qty rqr). Indicates the quantity of the item authorized to be used with/on the equipment.

Section II. COMPONENTS OF END ITEM

(Not applicable)

Section III. BASIC ISSUE ITEMS

(Not applicable)

APPENDIX C

ADDITIONAL AUTHORIZATION LIST

Section I. INTRODUCTION

C-1. SCOPE

This appendix lists additional items you are authorized for the support of the line printer.

C-2. GENERAL

This list identifies items that do not have to accompany the line printer and that do not have to be turned in with it. These items are all authorized to you by CTA, MTOE, TDA, or JTA.

C-3. EXPLANATION OF LISTING

National stock numbers, descriptions, and quantities are provided to help you identify and request the additional items you require to support this equipment. The items are listed in alphabetical sequence by item name under the type document (i.e., CTA, MTOE, TDA, or JTA) which authorizes the item(s) to you.

Section II. ADDITIONAL AUTHORIZATION LIST

(Not applicable)

APPENDIX D

EXPENDABLE SUPPLIES AND MATERIALS LIST

Section I. INTRODUCTION

D-1. SCOPE

This appendix lists expendable supplies and materials you will need to operate and maintain the line printer. These items are authorized to you by CTA 50-970, Expendable Items (Except Medical, Class V, Repair Parts, and Heraldic Items).

D-2. EXPLANATION OF COLUMNS

Column (1) -- Item number. This number is assigned to the entry in the listing and is referenced in the narrative instructions to identify the material (e.g., "Use cleaning compound, item 5, App. D").

Column (2) -- Level. This column identifies the lowest level of maintenance that requires the listed item.

- C -- Operator/Crew
- O -- Organizational Maintenance
- F -- Direct Support Maintenance

Column (3) -- National Stock Number. This is the National stock number assigned to the item; use it to request or requisition the item.

Column (4) -- Description. Indicates the Federal item name and, if required, a description to identify the item. The last line for each item indicates the Federal Supply Code for Manufacturer (FSCM) in parentheses followed by the part number.

Column (5) -- Unit of Measure (U/M). Indicates the measure used in performing the actual maintenance function. This measure is expressed by a two-character alphabetical abbreviation (e.g., ea, in., pr). If the unit of measure differs from the unit of issue, requisition the lowest unit of issue that will satisfy your requirements.

Section II. EXPENDABLE SUPPLIES AND MATERIALS LIST

(1) Item Number	(2) Level	(3) National Stock Number	(4) Description	(5) U/M
	C	8305-00-222-2423	Cloth, Lintfree	YD
	C	6810-00-753-4993	Alcohol, Isopropyl 81348 TTI735	CN

INDEX

SUBJECT	Page
A	
Abbreviations, list of	1-2
Acoustic cabinet	1-3
Adjustments, daily checks, self test, initial	2-8
Assembly and preparation for use	2-8
C	
Cabinet, acoustic	1-3
Character band	
check/adjust.	3-14
clean	3-16
remove/replace.	2-22
Check/adjust	
character band.	3-14
ribbon and ribbon cartridge	3-11
Clean	
character band.	3-16
line printer.	3-18
paper motion sensor	3-21
Components, paper handling	1-6
Controls and indicators	
electronic	2-2
mechanical	2-1
Cooling system	1-10
Cross-reference list, nomenclature	1-2
D	
Data, equipment	1-11
Description and use of operator's controls and indicators	2-1
Description	
equipment	1-3
functional	1-12
Decals and instruction plates, operating instructions on	2-38
E	
Emergency procedures	2-40
Equipment	
data	1-11
description	1-3
purpose, capabilities and features	1-3
Equipment improvement recommendations, reporting	1-1
Electronic controls	2-2
F	
Forms and records, maintenance	1-1
Functional description.	1-12

SUBJECT	Page
G	
Glossary	1-2
H	
Hand receipt (-HR) manuals	1-1
I	
Index of operating procedures	2-1
Index of maintenance procedures	3-1
Indicators, controls and	2-1
Information, reference	1-1
Initial adjustments, daily checks and self test	2-8
Install/remove	
paper	2-11
VFU tape	2-30
Instructions on decals and instruction plates, operating	2-38
Instructions	
lubrication	3-1
maintenance	3-1
operating	2-1
L	
Line printer	
clean	3-18
operate	2-35
power ON/power OFF.	2-9
self-test	2-35
List of abbreviations	1-2
List, nomenclature cross-reference	1-2
Location and description of major components	1-3
Lubrication instructions	3-1
M	
Maintenance	
checks and services, preventive	2-5
forms and records	1-1
instructions	3-1
procedures	3-10
procedures, index of.	3-1
Manuals, hand receipt (-HR)	1-1
Major components, location and description of	1-3
Mechanical controls	2-1
Mechanism, print.	1-8, 1-12
Movement, preparation for	2-38
N	
Nomenclature cross-reference list	1-2

SUBJECT	O	Page
Operate line printer		2-34
Operating		
instructions		2-1
instructions on decals and instruction plates		2-38
procedures.		2-8
procedures, index of.		2-1
Operation		
in unusual weather.		2-40
of auxiliary equipment		2-25
technical principles of		1-12
under unusual conditions		2-40
under usual conditions		2-8
Operator's controls and indicators, description of		2-1

P

Paper		
handling components		1-6
install/remove.		2-11
motion sensor, clean.		3-21
PMCS procedures		2-5
Power ON/power OFF line printer		2-9
Preparation for movement		2-38
Preparation for use, assembly and		2-8
Prepare VFU punched tape.		2-26
Preventive maintenance checks and services		2-5
principles of operation, technical		1-12
Print mechanism	1-8,	1-12
Procedures		
emergency		2-40
maintenance		3-10
operating		2-8
PMCS		2-5
troubleshooting		3-1
Punching VFU tape		2-25
Purpose, capabilities, and features, equipment		1-3

R

Reference information		1-1
Remove/replace		
character band.		2-22
ribbon cartridge		2-18
Reporting equipment improvement recommendations		1 - 1
Ribbon and ribbon cartridge, check/adjust		3-11
Ribbon cartridge, remove/replace		2-18

S

Self-test mode.		1-12
Self-test/operate line printer		2-34

SUBJECT	Page
T	
Technical principles of operation	1-12
Troubleshooting procedures	3-1
U	
Unusual conditions, operation under	2-40
Unusual weather, operation in	2-40
Usual conditions, operation under	2-8
V	
VFU punched tape, prepare	2-26
VFU tape, install/remove	2-30
VFU tape, punching.	2-25

By Order of the Secretary of the Army:

Official:

JOHN A. WICKHAM JR.
General, United States Army
Chief of Staff

DONALD J. DELANDRO
Brigadier General, United States Army
The Adjutant General

DISTRIBUTION:

To be distributed in accordance with

DA Form 12-15C, for AN/MYQ-4A.

RECOMMENDED CHANGES TO EQUIPMENT TECHNICAL PUBLICATIONS



THEN JOT DOWN THE DOPE ABOUT IT ON THIS FORM. CAREFULLY TEAR IT OUT. FOLD IT AND DROP IT IN THE MAIL.

SOMETHING WRONG WITH THIS PUBLICATION?

FROM (PRINT YOUR UNIT'S COMPLETE ADDRESS)

Commander
Stateside Army Depot
ATTN: AMSTA-US
Stateside, N.J. 07703

DATE SENT

10 July 1975

PUBLICATION NUMBER

TM 11-5840-340-12

PUBLICATION DATE

23 Jan 74

PUBLICATION TITLE

Radar Set AN/PRC-76

BE EXACT PIN-POINT WHERE IT IS

PAGE NO	PARA-GRAPH	FIGURE NO	TABLE NO
2-25	2-28		
3-10	3-3		3-1
5-6	5-8		
		F03	

IN THIS SPACE TELL WHAT IS WRONG AND WHAT SHOULD BE DONE ABOUT IT:

Recommend that the installation antenna alignment procedure be changed throughout to specify a 2° IFF antenna lag rather than 1°.

REASON: Experience has shown that with only a 1° lag, the antenna servo system is too sensitive to wind gusting in excess of 25 knots, and has a tendency to rapidly accelerate and decelerate as it hunts, causing strain to the drive train. Hunting is minimized by adjusting the lag to 2° without degradation of operation.

Item 5, Function column. Change "2 db" to "3db."

REASON: The adjustment procedure the the TRANS POWER FAULT indicator calls for a 3 db (500 watts) adjustment to light the TRANS POWER FAULT indicator.

Add new step f.1 to read, "Replace cover plate removed in step e.1, above."

REASON: To replace the cover plate.

Zone C 3. On J1-2, change "+24 VDC to "+5 VDC."

REASON: This is the output line of the 5 VDC power supply. +24 VDC is the input voltage.

PRINTED NAME, GRADE OR TITLE AND TELEPHONE NUMBER

SSG I. M. DeSpirito 999-1776

SIGN HERE

DA FORM 2028-2
1 JUL 79

PREVIOUS EDITIONS ARE OBSOLETE.

PS --IF YOUR OUTFIT WANTS TO KNOW ABOUT YOUR RECOMMENDATION MAKE A CARBON COPY OF THIS AND GIVE IT TO YOUR HEADQUARTERS

FILL IN YOUR
UNIT'S ADDRESS

FOLD BACK

DEPARTMENT OF THE ARMY

OFFICIAL BUSINESS
PENALTY FOR PRIVATE USE \$300

POSTAGE AND FEES PAID
DEPARTMENT OF THE ARMY
DOD 314



TEAR ALONG PERFORATED LINE

Commander
US Army Communications-Electronics Command
and Fort Monmouth
ATTN: DRSEL-ME-MP
Fort Monmouth, New Jersey 07703

FILL IN YOUR
UNIT'S ADDRESS

FOLD BACK

DEPARTMENT OF THE ARMY

OFFICIAL BUSINESS
PENALTY FOR PRIVATE USE \$300

POSTAGE AND FEES PAID
DEPARTMENT OF THE ARMY
DOD 314



TEAR ALONG DISSEPARATION LINE

Commander
US Army Communications-Electronics Command
and Fort Monmouth
ATTN: DRSEL-ME-MP
Fort Monmouth, New Jersey 07703

FILL IN YOUR
UNIT'S ADDRESS

FOLD BACK

DEPARTMENT OF THE ARMY

OFFICIAL BUSINESS
PENALTY FOR PRIVATE USE \$300

POSTAGE AND FEES PAID
DEPARTMENT OF THE ARMY
DOD 314



TEAR ALONG SEPARATING LINE

Commander
US Army Communications-Electronics Command
and Fort Monmouth
ATTN: DRSEL-ME-MP
Fort Monmouth, New Jersey 07703

RECOMMENDED CHANGES TO EQUIPMENT TECHNICAL PUBLICATIONS



THEN...JOT DOWN THE DOPE ABOUT IT ON THIS FORM. CAREFULLY TEAR IT OUT, FOLD IT AND DROP IT IN THE MAIL.

SOMETHING WRONG WITH THIS PUBLICATION?

FROM: (PRINT YOUR UNIT'S COMPLETE ADDRESS)

DATE SENT

PUBLICATION NUMBER

TM 11-7025-232-10

PUBLICATION DATE

13 May 85

PUBLICATION TITLE

Line Printer RP-309/MYQ-4A

BE EXACT PIN-POINT WHERE IT IS

PAGE NO.	PARA-GRAPH	FIGURE NO.	TABLE NO.

IN THIS SPACE TELL WHAT IS WRONG AND WHAT SHOULD BE DONE ABOUT IT:

TEAR ALONG PERFORATED LINE

PRINTED NAME GRADE OR TITLE AND TELEPHONE NUMBER

SIGN HERE

DA FORM 2028-2
1 JUL 79

PREVIOUS EDITIONS ARE OBSOLETE

P.S.--IF YOUR OUTFIT WANTS TO KNOW ABOUT YOUR RECOMMENDATION MAKE A CARBON COPY OF THIS AND GIVE IT TO YOUR HEADQUARTERS.

FILL IN YOUR
UNIT'S ADDRESS

FOLD BACK

DEPARTMENT OF THE ARMY

OFFICIAL BUSINESS
PENALTY FOR PRIVATE USE \$300

POSTAGE AND FEES PAID
DEPARTMENT OF THE ARMY
DOD 314



TEAR ALONG SEPARATING LINE

Commander
US Army Communications-Electronics Command
and Fort Monmouth
ATTN: DRSEL-ME-MP
Fort Monmouth, New Jersey 07703

